

Smoke and heat control systems —

Part 1: Specification for smoke barriers



ICS 13.220.99

National foreword

This British Standard is the UK implementation of EN 12101-1:2005+A1:2006. It supersedes BS 7346-3:1990 which is withdrawn.

The UK participation in its preparation was entrusted to Technical Committee FSH/25, Smoke, heat control systems and components.

A list of organizations represented on this committee can be obtained on request to its secretary.

WARNING

Amendment A1 to EN 12101-1 has been published by a majority decision with the UK voting against publication. The reason for the negative UK vote is that Technical Committee FSH/25 consider this amendment to be confusing, reducing clarity of the original document.

The start and finish of text introduced or altered by amendment is indicated in the text by tags $\boxed{A1}$ $\langle A1 \rangle$. Tags indicating changes to CEN text carry the number of the CEN amendment. For example, text altered by CEN amendment A1 is indicated in the text by $\boxed{A1}$ $\langle A1 \rangle$.

This publication does not purport to include all the necessary provisions of a contract. Users are responsible for its correct application.

Compliance with a British Standard cannot confer immunity from legal obligations.



This British Standard was published under the authority of the Standards Policy and Strategy Committee on 15 March 2006

© BSI 2009

ISBN 978 0 580 68171 4

Amendments/corrigenda issued since publication

| Amd. No. | Date | Comments |
|----------|-------------------|---|
| 16507 | 29 September 2006 | Implementation of CEN amendment A1:2006 |
| | 30 November 2009 | Supersession text added; alignment of BSI and CEN publication dates |
| | | |

ICS 13.220.99

English Version

Smoke and heat control systems - Part 1: Specification for smoke barriers

Systèmes pour le contrôle des fumées et de la chaleur -
Partie 1: Spécifications relatives aux écrans de
cantonnement de fumée

Rauch- und Wärmefreihaltung - Teil 1: Bestimmungen für
Rauchschürzen

This European Standard was approved by CEN on 16 January 2004.

CEN members are bound to comply with the CEN/CENELEC Internal Regulations which stipulate the conditions for giving this European Standard the status of a national standard without any alteration. Up-to-date lists and bibliographical references concerning such national standards may be obtained on application to the Central Secretariat or to any CEN member.

This European Standard exists in three official versions (English, French, German). A version in any other language made by translation under the responsibility of a CEN member into its own language and notified to the Central Secretariat has the same status as the official versions.

CEN members are the national standards bodies of Austria, Belgium, Cyprus, Czech Republic, Denmark, Estonia, Finland, France, Germany, Greece, Hungary, Iceland, Ireland, Italy, Latvia, Lithuania, Luxembourg, Malta, Netherlands, Norway, Poland, Portugal, Slovakia, Slovenia, Spain, Sweden, Switzerland and United Kingdom.



EUROPEAN COMMITTEE FOR STANDARDIZATION
COMITÉ EUROPÉEN DE NORMALISATION
EUROPÄISCHES KOMITEE FÜR NORMUNG

Management Centre: rue de Stassart, 36 B-1050 Brussels

Contents

page

| | | |
|---------|---|----|
| 0 | Introduction..... | 6 |
| 0.1 | General..... | 6 |
| 0.2 | Function of smoke barriers..... | 6 |
| 0.3 | Applications of smoke barriers..... | 7 |
| 0.4 | Types of smoke barrier..... | 7 |
| 1 | Scope..... | 8 |
| 2 | Normative references..... | 8 |
| 3 | Terms, definitions and symbols..... | 8 |
| 3.1 | General terms and definitions..... | 8 |
| 3.2 | Symbols..... | 10 |
| 4 | Product requirements..... | 11 |
| 4.1 | General..... | 11 |
| 4.2 | Barrier types..... | 11 |
| 4.3 | Auxiliary power supply..... | 12 |
| 4.4 | Smoke (fire effluent) leakage..... | 12 |
| 4.5 | Reliability..... | 13 |
| 4.6 | Response time..... | 13 |
| 5 | Performance requirements and classifications..... | 13 |
| 5.1 | General..... | 13 |
| 5.2 | Temperature/time classification..... | 13 |
| 5.3 | Reliability and durability of smoke barriers..... | 14 |
| 5.4 | Response time of active smoke barriers..... | 14 |
| 5.5 | Smoke leakage (containment efficiency)..... | 15 |
| 6 | Evaluation of conformity..... | 22 |
| 6.1 | General..... | 22 |
| 6.2 | Initial type testing..... | 23 |
| 6.3 | Factory product control (FPC)..... | 24 |
| 7 | Installation..... | 26 |
| 8 | Maintenance..... | 27 |
| 9 | Marking and labelling..... | 27 |
| Annex A | (normative) General testing requirements..... | 29 |
| A.1 | Principle..... | 29 |
| A.2 | Test sequence for initial type testing..... | 29 |
| A.3 | Test report..... | 29 |
| Annex B | (normative) Reliability and response time tests..... | 31 |
| B.1 | Test method for the reliability and the response time of the product and the durability of materials..... | 31 |
| B.2 | Test specimen..... | 31 |
| B.3 | Procedure..... | 31 |
| B.4 | Test report..... | 32 |
| Annex C | (normative) Permeability of materials to smoke..... | 33 |
| C.1 | Materials: Impermeable..... | 33 |
| C.2 | Materials: Permeable (permitting limited passage of smoke)..... | 33 |
| C.3 | Test procedure..... | 33 |
| C.4 | Test report..... | 33 |
| Annex D | (normative) Temperature/time resistance tests..... | 34 |

| | | |
|-----------------|---|-----------|
| D.1 | Test equipment..... | 34 |
| D.2 | Test specimen requirements | 34 |
| D.3 | Installation of test specimen into the support frame..... | 36 |
| D.4 | Test procedure..... | 37 |
| D.5 | Measurements and observations | 38 |
| D.6 | Test report..... | 39 |
| Annex E | (informative) Deflection of smoke barriers | 40 |
| E.1 | General | 40 |
| E.2 | Principle | 42 |
| E.3 | Barriers not reaching the floor | 44 |
| E.4 | Barriers closing an opening | 45 |
| E.5 | Smoke leakage through gaps in barriers..... | 46 |
| Annex ZA | (informative) Clauses of this European Standard addressing the provisions of the EU Construction Products Directive..... | 47 |
| ZA.0 | Scope of this annex..... | 47 |
| ZA.1 | Relationship between EU Directive and this European Standard..... | 47 |
| ZA.2 | Procedure for the attestation of conformity of smoke barriers | 48 |
| ZA.3 | CE marking..... | 48 |
| ZA.4 | Certificate and declaration of conformity | 49 |



Foreword

This European Standard (EN 12101-1:2005) has been prepared by Technical Committee CEN/TC 191 "Fixed firefighting systems", the secretariat of which is held by BSI.

This European Standard shall be given the status of a national standard, either by publication of an identical text or by endorsement, at the latest by February 2006, and conflicting national standards shall be withdrawn at the latest by August 2008.

This document has been prepared under a mandate given to CEN by the European Commission and the European Free Trade Association, and supports essential requirements of EU Directive 89/106/EEC.

For relationship with EU Directive(s), see informative Annex ZA, which is an integral part of this document.

This European Standard is one part of the European Standard EN 12101, which has the general title "Smoke and heat control systems" and consists of the following separate parts:

- Part 1: Specification for smoke barriers.
- Part 2: Specification for natural smoke and heat exhaust ventilators.
- Part 3: Specification for powered smoke and heat exhaust ventilators.
- Part 4: Fire and smoke control installations — Kits.
- Part 5: Guidelines on functional recommendations and calculation methods for smoke and heat exhaust ventilation systems (published as CR 12101-5).
- Part 6: Specification for pressure differential systems — Kits.
- Part 7: Smoke control ducts.
- Part 8: Specification for smoke control dampers.
- Part 9: Control panels.
- Part 10: Specification for power supplies.

EN 12101 is included in a series of European Standards planned also to cover:

- a) CO₂ systems (EN 12094 & EN ISO 14520);
- b) sprinkler systems (EN 12259);
- c) powder systems (EN 12416);
- d) explosion protection systems (EN 26184);
- e) foam systems (EN 13565);
- f) hose reel systems (EN 671);

g) water spray systems.

Annexes A to D are normative.

Annex E is informative.

This document includes a Bibliography.

According to the CEN/CENELEC Internal Regulations, the national standards organizations of the following countries are bound to implement this European Standard: Austria, Belgium, Cyprus, Czech Republic, Denmark, Estonia, Finland, France, Germany, Greece, Hungary, Iceland, Ireland, Italy, Latvia, Lithuania, Luxembourg, Malta, Netherlands, Norway, Poland, Portugal, Slovakia, Slovenia, Spain, Sweden, Switzerland and United Kingdom.

Foreword to amendment A1

This European Standard (EN 12101-1:2005/A1:2006) has been prepared by Technical Committee CEN/TC 191 "Fixed firefighting systems", the secretariat of which is held by BSI.

This Amendment to the European Standard EN 12101-1:2005 shall be given the status of a national standard, either by publication of an identical text or by endorsement, at the latest by September 2006, and conflicting national standards shall be withdrawn at the latest by December 2007.

This European Standard has been prepared under a mandate given to CEN by the European Commission and the European Free Trade Association, and supports essential requirements of EU Directive(s).

For relationship with EU Directive(s), see informative annex ZA, which is an integral part of this European Standard.

According to the CEN/CENELEC Internal Regulations, the national standards organizations of the following countries are bound to implement this European Standard: Austria, Belgium, Cyprus, Czech Republic, Denmark, Estonia, Finland, France, Germany, Greece, Hungary, Iceland, Ireland, Italy, Latvia, Lithuania, Luxembourg, Malta, Netherlands, Norway, Poland, Portugal, Romania, Slovakia, Slovenia, Spain, Sweden, Switzerland and United Kingdom.

0 Introduction

0.1 General

Smoke and heat exhaust ventilation systems (SHEVS) create a smoke free layer above the floor by removing smoke and heat, and thus improve the conditions for the safe escape and/or rescue of people and animals and the protection of property and permit the fire to be fought while still in its early stages.

The use of smoke and heat exhaust ventilation systems to create smoke free areas beneath a buoyant smoke layer has become widespread. Their value in assisting in the evacuation of people from construction works, reducing fire damage and financial loss by preventing smoke logging, facilitating fire fighting, reducing roof temperatures and retarding the lateral spread of fire is firmly established. For these benefits to be obtained it is essential that SHEVS operate fully and reliably whenever called upon to do so during their installed life. A SHEVS is a scheme of safety equipment intended to perform a positive role in a fire emergency.

Components for smoke and heat exhaust systems should be installed as part of a properly designed smoke and heat exhaust system.

SHEVS help to:

- keep the escape and access routes free from smoke;
- facilitate fire fighting operations by creating a smoke free layer;
- delay and/or prevent flashover and thus full development of the fire;
- protect equipment and furnishings and contents;
- reduce thermal effects on structural components during a fire;
- reduce damage caused by thermal decomposition products and hot gases.

For the purpose of this European Standard, a smoke barrier is deemed to be any form of barrier to the movement of fire effluent.

Smoke barriers control the movement of fire effluent within a construction works in the event of fire. Smoke barriers, when used within a smoke and heat control system, become a critical element of that system. If smoke barriers are not in their fire operational position, the system will not perform as designed. However, even in the event that other elements of the SHEVS do not function, smoke barriers in the fire operational position will provide essential smoke containment and channelling.

This European Standard applies to smoke barriers used within smoke and heat control systems, which include other equipment e.g. natural smoke and heat exhaust ventilators (EN 12101-2) and powered smoke and heat exhaust ventilators (EN 12101-3). Smoke barriers perform within specific time/temperature ranges.

0.2 Function of smoke barriers

The function of smoke barriers is to control the movement of fire effluent within construction works by forming a barrier. The functions of active or manually deployed smoke barriers are identical to those of static smoke barriers, but they also have the ability to be retracted and concealed when not in use.

Typical functions of smoke barriers are:

- to create a smoke reservoir by containing and limiting the travel of the smoke;
- to channel smoke in a pre-determined direction;
- to prevent or retard smoke entry to another area or void.

0.3 Applications of smoke barriers

The primary applications of smoke barriers are listed below. However, as their application becomes more widespread, it is inevitable they will be put to a wider variety of uses. It should be noted that, within the scope of this standard, smoke barriers can contain smoke and gases in excess of 600 °C but are not intended to perform the same function as fire barriers, smoke control doors which show conformity with (or are tested against) EN 1634-1 and -3, unless they meet the additional temperature requirements found in Table 2. Typical applications for smoke barriers are:

- smoke reservoir boundaries;
- channelling screens;
- void edge screens;
- void sealing screens;
- corridor containment;
- shop unit containment;
- escalator containment;
- stairwell containment;
- elevator well containment.



0.4 Types of smoke barrier

Construction works elements can be used to create static smoke barriers, and they can be augmented by smoke barriers covered by this standard.

This European Standard applies to the following types of smoke barriers:

- static smoke barriers: (SSB),
- active smoke barriers: (ASB).

A wide range of different materials may be used to create smoke barriers. Typical materials used for static smoke barriers include fabric, glass, metal, fire-resisting board, fibreglass and mineral wool or any impermeable material capable of resisting the smoke at temperatures required by the design.

Typical examples of active smoke barriers include roller, pleated, folding, hinged or sliding, using the types of material as described for static smoke barriers.

Static and active smoke barriers are categorized by type and performance in Clause 4.

In addition an ASB product is deemed to include all controlling equipment etc. This does not include external controls, for example a fire alarm or a sprinkler flow switch.

1 Scope

This part of EN 12101 specifies the product performance requirements, classifications and test methods for smoke barriers, which comprise the barrier itself, with or without associated activation and drive devices, designed for use in smoke and heat control systems. It covers only barriers installed in buildings, i.e. it does not cover barriers made of part of the building's structure. This standard provides the test methods for, and evaluation of conformity of, the smoke barrier systems.

2 Normative references

The following referenced documents are indispensable for the application of this document. For dated references, only the edition cited applies. For undated references, the latest edition of the referenced document (including any amendments) applies.

EN 1363-1, *Fire resistance tests — Part 1: General requirements*.

EN 1363-2, *Fire resistance tests — Part 2: Alternative and additional procedures*.

EN 1634-3, *Fire resistance tests for door and shutter assemblies - Part 3: Smoke control doors and shutters*.

prCEN/TR 12101-4, *Smoke and heat control systems — Part 4: Installed SHEVS systems for smoke and heat ventilation*.

EN ISO 9001, *Quality management systems — Requirements (ISO 9001:2000)*.

EN ISO 13943:2000, *Fire safety — Vocabulary (ISO 13943:2000)*.

3 Terms, definitions and symbols

3.1 General terms and definitions

For the purposes of this European Standard, the terms and definitions given in EN ISO 13943:2000 and the following apply.

3.1.1

active smoke barrier

smoke barrier which moves from its retracted position into its fire operational position automatically when called upon to do so

3.1.2

barrier movement

travel distance (e.g. height, drop) of an active barrier from its retracted position to its fire operational position

3.1.3

channelling screen

smoke barrier installed beneath a balcony or projecting canopy to direct the flow of smoke and hot gases from a room opening to the spill edge

3.1.4

consumable power supplies

any form of power that when not available will prevent an active smoke barrier moving to the required fire operational position

3.1.5

deflection

movement of a smoke barrier when subjected to the buoyant force of the hot smoke, the movement of air, air pressure, or any combination thereof

3.1.6

fail-safe

designed to return to a safe condition in the event of a failure or malfunction etc.

3.1.7

fire operational position

final configuration of a device e.g. a smoke barrier, specified by its designer to achieve and be sustained in the ultimate fire condition of the design

3.1.8

fitness for purpose

ability of a product, process or service to serve a defined purpose under specific conditions

3.1.9

free area

total area of all designed openings and clearance gaps in and/or around the perimeter of a smoke barrier

3.1.10

integrity

ability of a barrier to maintain its soundness for the purpose for which it is intended without the transmission of significant quantities of flames or hot gases to the non-exposed side

3.1.11

life safety application

application of the smoke and heat control system in its fire operational condition for the period of time required for the occupants of the premises to be alerted, and to be able to exit the premises, with the smoke and heat control system assisting in the protection of the means of escape

3.1.12

response time

time taken for an active smoke barrier to move to its fire operational position after initiation

3.1.13

smoke and heat exhaust ventilation system (SHEVS)

set of components jointly selected to exhaust smoke and heat in order to establish a buoyant layer of warm smoke above cooler, cleaner air

3.1.14

smoke and heat control system

arrangement of components installed in a construction works to limit the effects of smoke and heat from a fire

3.1.15

smoke barrier

device to channel, contain and/or prevent the migration of smoke (fire effluent)

NOTE Smoke Barriers can also be referred to as: Smoke Curtains, Smoke Blinds, Smoke Screens.

3.1.16

smoke reservoir

region within a construction works limited or bordered by smoke barriers or structural elements so as to retain a thermally buoyant smoke layer in the event of a fire

3.1.17

spill edge

edge of a soffit beneath which a smoke layer is flowing and adjacent to a void, e.g. the edge of a balcony or canopy, or the top edge of a window through which the smoke is flowing out of a room

3.1.18

static smoke barrier

smoke barrier permanently fixed in its fire operational position

3.1.19

void edge screen

smoke barrier deployed beneath the edge of a balcony or projecting canopy. Void edge screens can either be used to create a smoke reservoir beneath the balcony or canopy or to restrict the length of spill edge in order to create a more compact spill plume

3.1.20

void sealing screen

smoke barrier deployed across a void to create a smoke reservoir beneath the smoke barrier

3.2 Symbols

| | |
|-------------|---|
| A_g | Area of the gaps between smoke barriers, or between barrier and structure (m^2) |
| d_c | Horizontal deflection of a smoke barrier, measured at its bottom bar (m) |
| d_0 | Height of opening |
| D | Distance of movement (drop) of smoke barrier (mm) |
| D_1 | Design depth of a smoke layer in a reservoir (m) |
| G | Acceleration due to gravity (m/s^2) |
| h_b | Height of rise of a thermal line plume from an opening or balcony edge to the smoke layer (m) |
| h_p | Height of rise of leakage gases from the base of the hot gas layer in the smoke reservoir to the ceiling in the adjacent protected area (m) |
| L_c | Length of the smoke barrier from top to bottom bar, measured along the fabric (m) |
| M_b | Mass per metre length of the barrier's bottom bar (kg/m) |
| M_c | Mass per m^2 of the barrier fabric (kg/m^2) |
| M_B | Mass flow rate under a balcony (kg/s) |
| M_p | Mass of gas flowing into the gas layer in a protected area, having leaked through gaps in smoke barriers (kg/s) |
| $N_{1...3}$ | Number of each type of gap in smoke barrier |
| t | Time in minutes |
| T | Absolute temperature of gases (K) |
| T_1 | Absolute temperature of gas layer in a reservoir (K) |
| θ | Temperature rise above ambient of smoky gases in a reservoir ($^{\circ}C$) |
| ρ_o | Density of ambient air (kg/m^3) |
| W | Width of smoke barrier (mm) |

4 Product requirements

4.1 General

NOTE The smoke barrier requirements are intended to provide the SHEVS designers with smoke barriers which fulfil the system design requirements. Compliance with EN 12101-1 does not necessarily, by itself, ensure fitness for purpose for an application, as defined in ISO/IEC Guide 2:1996.

The system design parameters will dictate the minimum classification and performance of smoke barriers which can be used in any particular application. The criteria for the correct choice of smoke barrier shall take into account the total system, function and location requirements without hindering the means of escape or endangering the occupants.

4.2 Barrier types

4.2.1 General

Smoke barriers shall be defined as one of the following types:

- static smoke barrier - flexible material;
- static smoke barrier - rigid material;
- active smoke barrier - flexible material;
- active smoke barrier - rigid material.

4.2.2 Static smoke barriers (SSB)

Static smoke barriers shall be fixed in their fire operational position at all times and according to their design classification.

NOTE Static smoke barriers are used as alternatives and/or additional to the elements of the construction works which could act as permanent static smoke barriers.

4.2.3 Active smoke barriers (ASB)

Active smoke barriers shall move to the fire operational position upon external initiation and according to their design classification. Active smoke barriers shall be defined according to their application, e.g. life safety protection or property protection, method of operation and external initiations.

NOTE 1 Active smoke barriers are used as alternatives and/or additional to elements of the construction works which could act as permanent static smoke barriers.

Active smoke barriers shall be categorized as follows:

ASB1: Smoke barriers which fail safe in/to the fire operational position (not lower than 2,5 m above the finished floor level or in any location hazardous to occupants or objects), in a controlled manner (see 5.4) when all consumable primary and auxiliary power sources are removed, in the event of wiring or system corruption, or any combination thereof.

ASB2: Smoke barriers which move to/stay in the fire operational position (not lower than 2,5 m above the finished floor level or in any location hazardous to occupants or objects), in a controlled manner (see 5.4) upon external initiation but requiring a consumable power source in order to move to or be maintained in the fire operational position.

ASB3: Smoke barriers, conforming to type ASB1, which can be deployed to any height (see 5.4).

ASB4: Smoke barriers conforming to ASB2, which can be deployed to any height (see 5.4).

In the majority of applications active smoke barriers shall fail safe. But if it is necessary for the smoke barrier to remain retracted, even in the event of fail safe, the system shall be so designed and tested.

NOTE 2 ASB1 and ASB3 do not require fire rated cables or cable systems.

NOTE 3 Active Smoke Barriers without the fail safe facility i.e. those requiring a power source to drive them down (ASB2 and ASB4), require fire rated cables or cable systems in accordance with prCEN/TR 12101-4.

NOTE 4 In certain applications smoke barriers are used for life safety applications where types ASB1 and ASB3 may be more fit for purpose.

4.3 Auxiliary power supply

If batteries are used as the primary or auxiliary power source (types ASB2 and ASB4), batteries shall be submitted to an active battery test at intervals not exceeding 60 min. During this test the connected load shall be at least 110% of the normal motor current and shall be powered solely from the battery set. A fault indicating signal shall be given as a volt free contact and as an optical indication on the control panel upon:

- battery set insufficiently charged;
- faulty battery set (e.g. short circuit);
- battery set not connected to load (e.g. open circuit).

Upon detection of a fault signal the active smoke barrier shall move to the fire operational position.

Other stored energy systems shall have an equivalent level of monitoring and shall be capable of moving the barrier to its fire operational position upon detection of a fault signal.

Power supplies shall comply with regulatory requirements valid in the place of use.

4.4 Smoke (fire effluent) leakage

4.4.1 Openings, gaps and/or perimeter spaces

The free area through and around the complete system, materials and joints inherent in the product design shall be stated by the manufacturer.

All gaps in and around all types of smoke barrier shall be minimized to maintain the smoke barrier containment efficiency as defined in 5.5.

Deflection of a smoke barrier may occur due to pressure differences or air movement. This may increase edge gaps or reduce effective smoke reservoir depth. The system design shall take this into consideration (see 5.5.2).

NOTE 1 Care should be taken to ensure that any adjacent surfaces which form part of the barrier to smoke, e.g. false ceilings or fittings, have at least equivalent properties as the smoke barrier e.g. resistance to temperature and permeability (see prCEN/TR 12101-4).

NOTE 2 The above criteria require consideration to ensure the efficiency of the smoke barrier to control the movement of fire effluent and aid the effectiveness of the SHEVS.

4.4.2 Permeability of materials

The smoke barrier shall be manufactured from materials which restrict the passage of smoke (see Annex C and 5.5.5).

Where a specific system leakage rate is required, a complete product shall be tested to EN 1634-3 (see 5.5.5).

4.5 Reliability

The reliability of smoke barriers shall be determined in accordance with 5.3.

4.6 Response time

The response time of active smoke barriers shall conform to 5.4.

5 Performance requirements and classifications

5.1 General

Smoke barriers shall be tested in the orientation and use intended by the manufacturer for their application and installation.

5.2 Temperature/time classification

The temperature/time classifications of all smoke barriers shall be determined in accordance with the test methods in Annex D.

Smoke barriers shall be classified in accordance with the classification categories in Table 1.

Table 1 — Standard classification categories

| Classification | Temperature (°C) | Time (min) |
|----------------|------------------|-------------------------------|
| D 30 | 600 | 30 |
| D 60 | 600 | 60 |
| D 90 | 600 | 90 |
| D 120 | 600 | 120 |
| DA | 600 | Actual time reached above 120 |

The heat exposure at 600°C, designated D, represents the constant temperature of the smoke barrier test. The designations 30, 60, 90, 120 represent the period of the smoke barrier test. A smoke barrier which meets the requirements of D 60 also meets the requirements of D 30; equally, a D 90, or D120, smoke barrier also meets the requirements of D 60 and D 30, and D90, respectively. A DA smoke barrier meets all D requirements.

If smoke barriers are to operate at higher time/temperature ranges, they shall be classified in accordance with the classification categories in Table 2. The testing shall meet the time temperature requirements of EN 1363-1.

Table 2 — Classification categories for smoke barriers operating at higher temperatures

| Classification | Temperature (°C) | Time (min) |
|----------------|---------------------------------------|-------------------------------|
| DH 30 | Standard heating curve (EN 1363-1) | 30 |
| DH 60 | As above | 60 |
| DH 90 | As above | 90 |
| DH 120 | As above | 120 |
| DHA | As above | Actual time reached above 120 |

The performance requirements of smoke barrier test specimens when tested in accordance with Annex D are as follows.

- a) Test specimens shall conform to A.1.
- b) Test specimens shall maintain integrity, without either:
 - 1) permitting the penetration of a gap gauge (except for those free areas defined in 4.4.1 and 5.5);
 - 2) resulting in sustained flaming;
 - 3) collapsing.
- c) Test specimens shall not release flaming droplets or particles within the first 600 s when tested in accordance with this standard.

NOTE Observation of any components or droplets falling during the test will be recorded in the test report. When selecting a barrier for a particular application where falling components would be considered a significant threat to occupants, for example where people are expected to escape beneath smoke barriers, the full test report should be obtained and checked.

5.3 Reliability and durability of smoke barriers

5.3.1 Reliability and durability of smoke barriers — Static smoke barriers

The manufacturer/supplier shall provide verification that the materials used for static smoke barriers are fit for the purpose intended. For integrity and perforations see B.3, and for gaps see 5.5.3.

NOTE This should be done taking into account, for example, breaking loads, tear strength, flexural strength and resistance to flexing requirements valid in the place of use.

5.3.2 Reliability of smoke barriers — Active smoke barriers

Active smoke barrier specimens conforming to A.1 shall be tested in accordance with the reliability test in Annex B and shall complete the required number of cycles and shall then not allow the passage of either of the defined gap gauges (except for those free areas defined in 4.4.1 and 5.5).

5.4 Response time of active smoke barriers

Active smoke barrier specimens conforming to A.1 shall be tested in accordance with the response time test in annex B and shall operate within the velocity ranges specified in this clause.

Active smoke barrier specimens types ASB1 and ASB2 shall commence movement immediately upon initiation or any initiation failure and move to their operational position, in all operating modes, at a velocity range of between 0,06 m/s and 0,30 m/s.

Active smoke barriers types ASB3 and ASB4 which may be located in critical areas of a construction works, e.g. escape routes, entrances/exits to escalators or stairways, shall have a velocity range of 0,06 m/s – 0,15 m/s.

NOTE 1 Active smoke barriers with long barrier movements while conforming to 5.4 that cannot be fully deployed within 60 s can nevertheless provide progressive protection. Such operation should not compromise SHEVS design e.g. if one barrier is designed to protect multiple floors around an atrium, when the fire occurs on a lower floor, the protection to higher floors can be delayed.

NOTE 2 Precautions should be taken to ensure that descending barriers in such areas do not cause injury, panic, confusion etc., e.g. the use of visual or audible warnings, and partial and progressive descent of barriers should be considered.

NOTE 3 The above criteria require consideration to ensure the efficiency of the smoke barrier to control the movement of fire effluent and aid the effectiveness of the SHEVS.

5.5 Smoke leakage (containment efficiency)

5.5.1 General

Smoke barriers have a functional requirement to channel, contain and/or prevent the migration of smoke (fire effluent). The provisions of 5.5.2 to 5.5.5 shall therefore be followed.

5.5.2 Gaps and leakage areas

Operational gaps and/or areas of leakage of a barrier shall be stated for the product by the manufacturer (see Figures 1 to 10 which illustrate possible operational gaps required by the design of roller type smoke barrier applications). These gaps may increase under fire conditions, see Annex E.

NOTE 1 Barriers can require operational tolerances e.g. static barriers installed in buildings with expansion characteristics or active barriers at corners.

NOTE 2 The system designer, when calculating for a specific installation, should take containment efficiency into consideration.

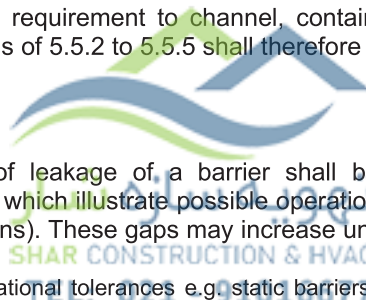

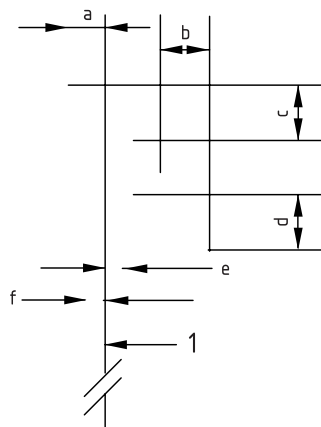

Key

1 Barrier

NOTE Smoke flow through the head box is controlled by the smallest gap when the barrier is in the fire operational position. Gaps a - f are representative of the potential smallest gaps. It is recommended to use the gap a - f with the smallest value.

Figure 1 — Potential gaps within a header box when barrier deployed

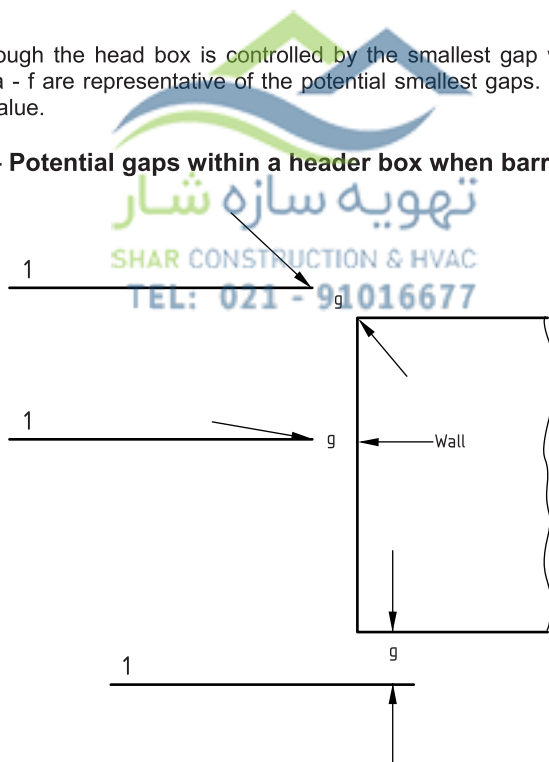

Key

g Gap

1 Barrier

2 Wall

Figure 2 — Potential edge gaps between the barrier and surrounding construction

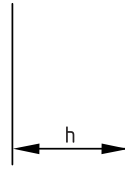

Key

h Gap

NOTE The gap is measured with the barriers in their fire operational position.

Figure 3 — Gaps between adjacent barriers when overlapped but not conjoined



Key

i Maximum gap when barriers are in the fire operational condition $h = i/2$

Figure 4 — Gaps between adjacent barriers when overlapped and conjoined



Figure 5 — Barriers overlapped to have no gaps at the overlap



Key

h Gap

NOTE The gap shown is in the passive condition.

Figure 6 — Adjacent barriers with no overlap

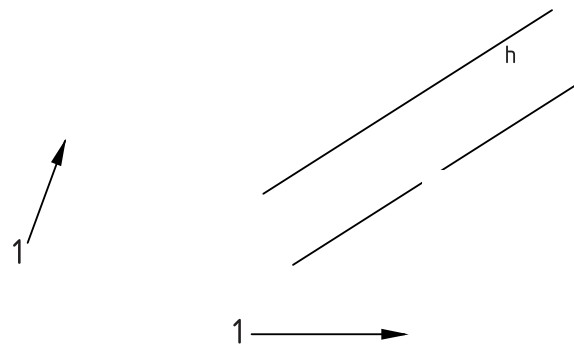

Key

1 Barrier

h Gap

NOTE To prevent independent barrier movement the bottom of the barriers should be conjoined at the corner.

Figure 7 — Adjacent barriers at a corner

5.5.3 Openings, gaps and/or perimeter spaces

Smoke barriers which do not require functional tolerances shall have all gaps sealed to prevent smoke leakage.

A1 Active smoke barriers shall be overlapped and conjoined where they are fixed in a straight line to prevent leakage. Where this cannot be achieved or if products are manufactured otherwise, the designer shall make allowances for increased leakage within his calculations (see Annex E). **A1**

Dimensions of gaps shall be used to calculate the smoke barrier system's total free area created by individual or total gaps. For the typical roller barriers shown in Figures 1 to 9 these are: **A1**

Gap_{head} (a to f) (mm)

Gap_{edge} (g) (mm)

Gap_{joint} (h) (mm)

Area_{head} = W x Gap_{head} (mm²)

Area_{edge} = D x Gap_{edge} (mm²)

Area_{joint} = D x Gap_{joint} (mm²)

Area_{total} = N₁ . Area_{head} + N₂ . Area_{edge} + N₃ . Area_{joint}

NOTE 1 For functional reasons gaps can be required between the barrier and the construction works, and for angled and adjacent barriers. In these cases any gap, based on the maximum travel distance specified by the manufacturer should not exceed:

a) 20 mm for barriers which travel up to and including 2 m;

b) 40 mm for barriers which travel from 2 m up to and including 6 m;

c) 60 mm for barriers which travel more than 6 m.

NOTE 2 For static barriers the expansion and contraction characteristics of the construction works should be taken into account when calculating the gaps. The fixing of the barrier to the structure, the load and the temperature should be verified. The load comprises the barrier's own mass, side pressure from the fire-side (20 Pa) and a safety coefficient. The minimum dilatation gap should be left. When panels are used to form the barrier, the connections should be tight and resistant to load and temperature (see Figure 8).

NOTE 3 Static and active smoke barriers can require functional tolerances, within the construction of the smoke barrier assembly itself, between the smoke barrier, another barrier and/or the construction works.

NOTE 4 Any gaps within a smoke barrier system should not prejudice the fitness for purpose of the system in accordance with the system design. Any gaps above or around the smoke barrier assembly in the smoke reservoir should be sealed or minimized.

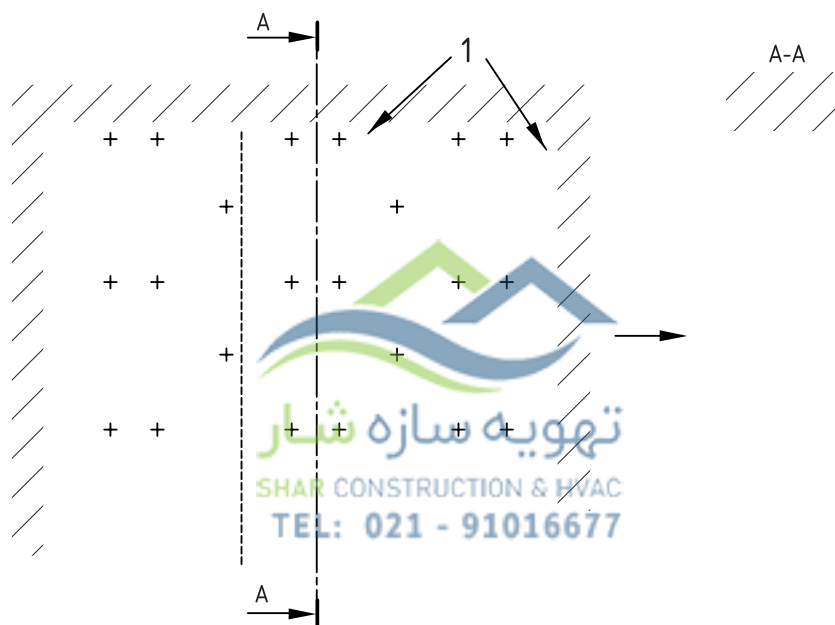

Key

1 Barrier

Figure 8 — Example of static smoke barrier, flexible or rigid material

5.5.4 Deflection

Static and active smoke barriers shall perform in accordance with the functional requirements of the system design, other SHEVS design requirements and construction works requirements, for the intended application.

In all tests, the smoke barrier shall be mounted as in practice, including the specified barrier mass and tensioning force, where required to reduce deflection. Deflection shall be assessed using a suitable method of calculating deflection to ensure that it is valid for the application. A method of calculating deflection is given in Annex E.

Smoke barriers in continuous, overlapped and conjoined runs provide additional resistance to deflection and smoke leakage. The gaps between adjacent smoke barriers conforming to 5.5.3 will be

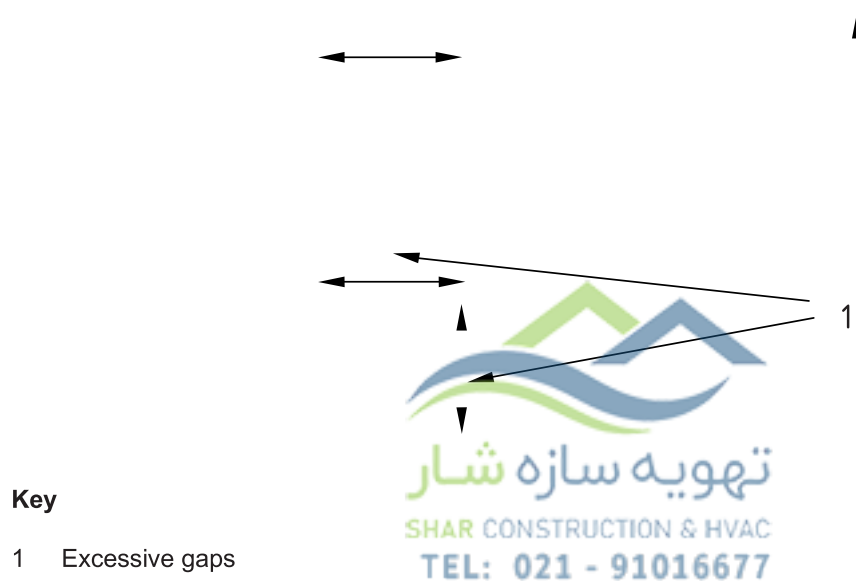

Figure 10 — Example of excess gap caused by deflection

5.5.5 Permeability of materials

Smoke barriers shall be manufactured from materials conforming to Annex C with a maximum leakage rate of $25\text{m}^3/\text{h}/\text{m}^2$ at 25 Pa at ambient temperature or 200 °C.

6 Evaluation of conformity

6.1 General

The compliance of a smoke barrier with the requirements of this standard shall be demonstrated by:

- initial type testing;
- factory production control.

NOTE The manufacturer is a natural or legal person, who places the product on the market under his own name. Normally, the manufacturer designs and manufactures the product himself. As a first alternative, he can have it designed, manufactured, assembled, packed, processed or labelled by subcontracting. As a second alternative he can assemble, pack, process, or label ready-made products.

The manufacturer shall ensure:

- that the initial type testing in accordance with this European Standard is initiated and carried out (where relevant, under the control of a product certification body); and
- that the product continuously complies with the initial type testing samples, for which compliance with this European Standard has been verified.

The manufacturer shall always retain the overall control and shall have the necessary competence to take responsibility for the product.

The manufacturer, when affixing the CE marking to the product, is fully responsible for the conformity of that product to all relevant regulatory requirements. However, where the manufacturer uses components already shown to conform to those requirements relevant for that component (e.g. by CE marking) the manufacturer is not required to repeat the evaluation which lead to such conformity. Where the manufacturer uses components not shown to conform, it is his responsibility to undertake the necessary evaluation to show conformity.

6.2 Initial type testing

6.2.1 General

Initial type testing shall be performed to demonstrate conformity with this European Standard.

All characteristics given in Clauses 4 and 5 shall be subject to initial type testing, except as described in 6.2.3. Tests shall be carried out in accordance with Annexes A, B, C and D.

NOTE Materials which conform to certain performance requirements for fire resistance, impermeability, etc., for example steel plate, may not require testing. However this does not necessarily constitute fitness for purpose for an application.

As the objective of the general testing procedures is to establish the ability of the smoke barrier to achieve the product design and performance requirements and classification in its operational position, and to continue to act as a barrier to smoke and heat for a designated period of time, the complete product (i.e. including motors and fixings) to be installed shall be tested.

6.2.2 Modifications

In the case of modification of the product or of the method of production (where these may affect the stated properties), initial type testing shall be performed. All characteristics given in Clauses 4 and 5, which may be changed by the modification, shall be subject to this initial type testing, except as described in 6.2.3.

6.2.3 Previous tests and product families

Tests previously performed in accordance with the provisions of this standard may be taken into account providing that they were made to the same or a more rigorous test method under the same system of attestation of conformity on the same product or products of similar design, construction and functionality, such that the results are applicable to the product in question.

Products may be grouped into families where one or more characteristics are the same for all products within that family or the test results are representative of all products within that family. In this case not all products of the family have to be tested for the purposes of the initial type testing.

6.2.4 Test samples

Test samples shall be representative of the normal production. If the test samples are prototypes, they shall be representative of the intended future production and shall be selected by the manufacturer.

If the technical documentation of the test samples does not give a sufficient basis for later compliance checks, a reference sample (identified and marked) shall remain available for this purpose.

6.2.5 Test report

Any initial type testing and its results shall be documented in a test report.

6.3 Factory product control (FPC)

6.3.1 General

The manufacturer shall establish, document and maintain an FPC system to ensure that the products placed on the market conform with the stated performance characteristics. FPC is the permanent internal control of production exercised by the manufacturer.

If the manufacturer has the product designed, manufactured, assembled, packed, processed and labelled by subcontracting, FPC of the original manufacturer may be taken into account. However, where subcontracting takes place, the manufacturer shall retain the overall control of the products and ensure that he receives all the information that is necessary to fulfil his responsibilities according to this European Standard. The manufacturer who subcontracts all of his activities may in no circumstances pass his responsibilities on to a subcontractor.

All the elements, requirements and provisions adopted by the manufacturer shall be documented in a systematic manner in the form of written policies and procedures. This production control system documentation shall ensure a common understanding of conformity evaluation and enable the achievement of the required component characteristics and the effective operation of the production control system to be checked.

TEL: 021 - 91016677

Factory production control therefore brings together operational techniques and all measures allowing maintenance and control of the conformity of the product with its technical specifications. Its implementation may be achieved by controls and tests on measuring equipment, raw materials and constituents, processes, machines and manufacturing equipment and finished products, including material properties in products, and by making use of the results thus obtained.

6.3.2 General requirements

The FPC system shall be part of a Quality Management system, e.g. in accordance with EN ISO 9001.

6.3.3 Product specific requirements

6.3.3.1 The FPC system shall

- address this European Standard; and
- ensure that the products placed on the market conform with the stated performance characteristics.

6.3.3.2 The FPC system shall include a product specific FPC- or Quality-plan, which identifies procedures to demonstrate conformity of the product at appropriate stages, i.e.

- a) the controls and tests to be carried out prior to and/or during manufacture according to a frequency laid down; and/or
- b) the verifications and tests to be carried out on finished products according to a frequency laid down.

If the manufacturer uses finished products, the operations under b) shall lead to an equivalent level of conformity of the product as if normal FPC had been carried out during the production.

If the manufacturer carries out parts of the production himself, the operations under b) may be reduced and partly replaced by operations under a). Generally, the more parts of the production that are carried out by the manufacturer, the more operations under b) may be replaced by operations under a). In any case the operation shall lead to an equivalent level of conformity of the product as if normal FPC had been carried out during the production.

NOTE Depending on the specific case, it can be necessary to carry out the operations referred to under a) and b), only the operations under a) or only those under b).

The operations under a) centre as much on the intermediate states of the product as on manufacturing machines and their adjustment, and test equipment etc. These controls and tests and their frequency are chosen based on product type and composition, the manufacturing process and its complexity, the sensitivity of product features to variations in manufacturing parameters etc.

The manufacturer shall establish and maintain records which provide evidence that the production has been sampled and tested. These records shall show clearly whether the production has satisfied the defined acceptance criteria. Where the product fails to satisfy the acceptance measures, the provisions for non-conforming products shall apply, the necessary corrective action shall immediately be taken and the products or batches not conforming shall be isolated and properly identified. Once the fault has been corrected, the test or verification in question shall be repeated.

The results of controls and tests shall be properly recorded. The product description, date of manufacture, test method adopted, test results and acceptance criteria shall be entered in the records under the signature of the person responsible for the control/test. With regard to any control result not meeting the requirements of this European Standard, the corrective measures taken to rectify the situation (e.g. a further test carried out, modification of manufacturing process, throwing away or putting right of the product) shall be indicated in the records.

6.3.3.3 Individual products or batches of products and the related manufacturing details shall be completely identifiable and retraceable.

6.3.4 Initial inspection of factory and FPC

6.3.4.1 Initial inspection of factory and FPC shall generally be carried out when the production is already running and the FPC is already in practice.

It is, however, possible that the initial inspection of factory and FPC is carried out before the production is already running and/or before the FPC is already in practice.

6.3.4.2 The following shall be assessed:

- the FPC-documentation; and
- the factory.

In the assessment of the factory it shall be verified,

- a) that all resources necessary for the achievement of the product characteristics required by this European Standard are or will be (see 6.3.4.1) available;

- b) that the FPC-procedures in accordance with the FPC-documentation are or will be (see 6.3.4.1) implemented and followed in practice;
- c) that the product complies or will comply (see 6.3.4.1) with the initial type testing samples, for which compliance with this European Standard has been verified; and
- d) whether the FPC system is part of a Quality Management system in accordance with EN ISO 9001 (see 6.3.2) and as part of this Quality Management system is certified and has yearly surveillance by a certification body, who is recognised by an accreditation body which is member of the "European Co-operation for Accreditation" and which has signed the "Multilateral agreement" (MLA) there.

6.3.4.3 All factories of the manufacturer where, for the relevant product, final assembling and/or final testing is performed, shall be visited to verify that the conditions of 6.3.4.2 a) to c) are in place. One visit may cover one or more products, production lines and/or production processes. If the FPC system covers more than one product, production line or production process, and if it is verified that the general requirements are fulfilled then the detailed verification of the product-specific FPC requirements for one product may be taken as representative of the FPC of other products.

6.3.4.4 Assessments previously performed in accordance with the provisions of this standard may be taken into account providing that they were made to the same system of attestation of conformity on the same product or products of similar design, construction and functionality, such that the results may be considered applicable to the product in question.

6.3.4.5 Any assessment and its results shall be documented in a report.

6.3.5 Continuous surveillance of FPC

6.3.5.1 All factories which have been assessed according to 6.3.4 shall be re-assessed once a year, except as stated in 6.3.5.2. In this case each FPC visit shall verify a different product or production process.

6.3.5.2 In the case of third party certification, if the manufacturer provides proof of continuing satisfactory operation of his FPC system the frequency of the re-assessment may be reduced to once every four years.

NOTE 1 Sufficient proof can be the report of a certification body, see 6.3.4.2 d).

NOTE 2 If the overall Quality Management system in accordance with EN ISO 9001 is well implemented (verified in the initial assessment of factory and FPC) and continuously practised (verified in QM-audits), it can be assumed that the integrated FPC-relevant part is well covered. On this basis, the work of the manufacturer is well surveyed, so that the frequency of special FPC-surveillance assessments can be reduced.

6.3.5.3 Any assessment and its results shall be documented in a report.

6.3.6 Procedure for modifications

In the case of modification of the product, the method of production or the FPC system (where these may affect the stated properties), a re-assessment of the factory and of the FPC system shall be performed for those aspects which may be affected by the modification.

Any assessment and its results shall be documented in a report.

7 Installation

The smoke barrier installation shall comply with the requirements of prCEN/TR 12101-4.

The supplier shall provide appropriate installation information, which shall include the following:

- a) fixing component information;
- b) power requirements and connections (active smoke barriers only);
- c) installation instructions including perimeter requirements where applicable;
- d) commissioning procedure;
- e) operating instruction (active smoke barriers only);
- f) warnings to avoid obstructions to operation (active smoke barriers only);
- g) penetrations (static only);
- h) operating instructions, with maximum operating and loading tolerance for the product, e.g. maximum barrier weight, bottom bar weights, minimum/maximum motor speeds, overlapping and conjoining, and fixing methods.

NOTE Care should be taken to ensure that the operation of an active smoke barrier is not obstructed, e.g. by cosmetic finishes, lighting, shelving, sales displays or racking.

8 Maintenance

In order to ensure continued compliance, reliability and integrity, smoke barriers shall be inspected, serviced and tested as defined in prCEN/TR 12101-4 by personnel trained and qualified in the product.

The supplier shall provide maintenance and testing information which shall include the following:

- a) inspection and maintenance procedure;
- b) recommended procedures for operational checks;
- c) recommended check for obstructions to operation, e.g. by cosmetic finishes, lighting, shelving, sales displays or racking;
- d) recommended check for the effects of corrosion, etc;
- e) recommended check for mechanical fastenings;
- f) recommended check for power supplies and controls;
- g) recommended check for penetrations, holes, etc;
- h) recommended check for anything which materially affects the performance of the product.

9 Marking and labelling

Smoke barriers conforming to this European Standard shall be marked (on the product itself or on its accompanying commercial documents) with the following:

- the number of this European Standard (EN 12101-1), and
- the product, i.e. static smoke barrier; active smoke barrier, and

- the application type i.e. ASB1; ASB2; ASB3 or ASB4 as shown in 4.2;
- installation and maintenance requirements;
- the fire resistance classification (D or DH), and
- the response delay (active barriers only), and
- ☐_{A1} — the openings, gaps and free areas (see 5.5.3), and ☐_{A1}
- the maximum material permeability (if less than 25 m³/m²/h).

Where ZA.3 covers the same information as this clause, the requirements of this clause are met.



Annex A (normative)

General testing requirements

A.1 Principle

Tests carried out in Annexes B, C and D shall be representative of all sizes and field of applications in the family, if products are to be grouped into families (see 6.2.4).

The supplier shall provide, with the test specimen, engineering drawings, calculations and parameters e.g. equivalent smoke barrier dimensions (as defined in B.2) and joints to prove that all sizes in the family are represented by the test specimen. An assessment shall be made to endorse proposed sizes and end uses of the finished product.

The following performance requirement tests shall be performed for smoke barriers:

- a) reliability and durability of product (see Annex B for active smoke barriers only);
- b) default operation to fire operation position (see Annex B for active smoke barriers only);
- c) response time and performance (see Annex B for active smoke barriers only);
- d) permeability to smoke (see Annex C);
- e) temperature/time classification (see Annex D).

A.2 Test sequence for initial type testing

The tests shall be carried out in the following sequence:

- a) reliability and durability;
- b) default operation to fire position;
- c) response time;
- d) permeability;
- e) temperature/time.

The same active smoke barrier shall be used for the reliability test (see B.2) and subsequently the temperature/time test (see Annex D).

A.3 Test report

A test report shall be prepared in accordance with the appropriate requirements of A.1 and A.2 to include the following:

- a) name or trademark, and address of the manufacturer and/or supplier;

- b) name of the product (type and model);
- c) date/s of the test/s;
- d) name/s and address/es of the testing organisation;
- e) full and detailed description of the test specimen, which shall include any comments regarding the family, the material integrity, weight and tensioning, if appropriate;
- f) reference to the test method/s;
- g) observations during the test/s;
- h) approved fixing methods;
- i) test results and classifications achieved.

These observations shall include any comments regarding the suitability of the smoke barrier to meet the functional requirements which may affect it or its fitness for purpose.



Annex B (normative)

Reliability and response time tests

A1) B.1 Test method for the reliability and the response time of the product and the durability of materials

The smoke barrier shall be tested in the reliability and response time tests with its intended control system used to govern speed of operation. The control system / panel shall meet the requirements of prEN 12101-9. Adjustable speed controls shall not be further adjusted during the test after initial setting. **A1)**

B.2 Test specimen

Where the manufacturer produces only one size and type of product, only one specimen shall be tested.

Where the manufacturer produces a range of products, at least two specimens shall be tested separately as follows.

One specimen shall have a maximum width of 3 m and a barrier movement of 10 m (or the maximum barrier movement offered by the supplier if less than 10 m). This specimen shall be used for the tests in Annex D.

The other specimen shall have a minimum width of 10 m (or the largest width in the family if smaller than 10 m) and a minimum barrier movement of 3 m. Where the supplier offers a barrier movement smaller than the minimum barrier movement, the maximum barrier movement of the family shall be used. Where the supplier offers multiple active smoke barriers which overlap, physically interact or are mechanically connected, the specimen shall be assembled in the manufacturer's normal manner to simulate a single active smoke barrier of 10 m width. This specimen shall have a minimum barrier movement of 3 m or the largest in the family. Where it is not possible to test the largest in the family, the minimum test barrier movement shall be 60 % of the claimed maximum barrier movement.

All relevant test criteria shall be increased/compensated to simulate the claimed maximum barrier movement. e.g. weight increased, number of moving parts, number of test cycles increased.

Tests on these two specimens shall be considered representative of all smoke barriers in their particular family.

A1) Static barriers shall be tested in a 3 m × 3 m furnace using the manufacturer's stated methods of manufacture, fixings and sealing. **A1)**

B.3 Procedure

Mount the specimens, using normal fixings in accordance with the sponsor's installation information.

Operate each ASB specimen 1 000 complete cycles using the primary energy source.

If the specimen uses any auxiliary power source for any part of its function e.g. gravity, battery, generator, air reservoir the 1 000 complete cycle test shall be followed by 50 complete cycles using the auxiliary power source to move the smoke barrier to its fire operational position.

NOTE A cycle is defined as moving the smoke barriers from the fully retracted position to the fire position and back to the fully retracted position.

No limit is set to the cycle period but the smoke barriers shall move to the fire operational position within the limits set in 5.4. However, the cycle period tested shall constitute the minimum cycle period for the specimen.

If movement to a non fire operational position is also a requirement, the specimen shall be tested to show that the required number of cycles (1 000) can be achieved within the required cycle period.

No maintenance or repair shall be permitted during the test period.

A consumable energy source may be replaced or recharged as necessary during the 50-cycle period but not during any single cycle. Where the primary energy source is supplied via a battery this source may be replaced by a power supply unit having an equivalent output.

Measure and record the cycle time and the time taken for each smoke barrier to reach the fire position at the beginning and end of the test period.

Measure and record the operating speeds in both directions of operation.

At the end of the test examine and record the finished specimen in its fire position and verify against the test criteria. Inspect the condition of the specimen, verify the integrity of the materials used according to EN 1363-1.

Check material for integrity and perforations, tears or cracks and whether a 6 mm diameter ball or a 15 mm × 2 mm strip will pass easily through either at the end of the test period.

Any actions and observations taken shall be recorded.



B.4 Test report

The test report shall be written and information provided in accordance with the requirements of Annex A.

Annex C (normative)

Permeability of materials to smoke

C.1 Materials: Impermeable

The impermeability of the material e.g. sheet metal shall be confirmed in writing and may be deemed acceptable without test.

C.2 Materials: Permeable (permitting limited passage of smoke)

Barrier materials that have not previously shown imperviousness to smoke (or are not deemed acceptable according to C.1) shall be tested in accordance with EN 1634-3, using a 1 m² sample with edges tightly sealed.

The passage of smoke through materials shall be restricted and shall not exceed a leakage rate of 25 m³ per hour per m² at ambient temperature or 200 °C when tested using the test procedures defined in EN 1634-3.

Materials likely to change performance when subjected to temperature/time shall be assessed.

C.3 Test procedure

Take a representative sample of material (see D.2.1) to include typical seams and joints and test to 25 Pa at ambient temperature or 200 °C. The material shall be deemed to have passed if the leakage rate is less than 25m³/h per m² at 25 Pa at ambient temperature or 200 °C.

C.4 Test report

The test report shall be written and information provided in accordance with the requirements of Annex A.

Annex D (normative)

Temperature/time resistance tests

D.1 Test equipment

The apparatus used in this test shall be in accordance with EN 1363-1.

D.1.1 *High temperature furnace*, with an aperture at least 3 m × 3 m.

D.1.2 *Support frame*, with an aperture at least 3 m × 3 m.

D.1.3 *Pressure measuring device*.

D.1.4 *Furnace thermocouples*, used to measure the average temperature at the exposed surface of the test specimen. There shall be at least one thermocouple for every 1,5 m² of exposed surface.

D.2 Test specimen requirements

D.2.1 Test specimen

The test specimen of an active smoke barrier shall be the same specimen previously tested in Annex B, being suitably modified with minimum intervention to reduce the drop to fit the furnace aperture with the offcut, if sufficiently large, being used for the permeability test in Annex C. The test specimen of a static barrier shall meet the requirements of this Annex.

D.2.2 Test specimen materials

Materials used in the construction of the test specimen, the method of construction and all fixings shall be as defined in Annex A. All normal fixing methods shall be submitted for approval. The most critical normal fixing method shall be selected as representative of the family to cover all fixing methods. The smoke barrier shall be tested in the orientation and standard use of its application and installation as recommended by the manufacturer and/or supplier.

D.2.3 Support frame

The test specimen, which is representative of the largest in the family, shall be tested within the support frame (see Figures D.1 and D.2).

For barriers where the largest size is less than 3 m × 3 m, the largest barrier in the family shall be tested.

For barriers where the largest size is greater than 3 m × 3 m, a 3 m × 3 m specimen shall be tested. To represent deeper barriers an additional load shall be applied evenly across the bottom of the barrier, equivalent to the additional mass per tested width of the deepest barrier in the family.

Barriers with any side guides and/or channels shall be tested with these, as part of the test specimen (see Figure D.1). If the test sample is not provided with side channels, these shall be provided by either the sponsor/supplier or the test laboratory when necessary (see D.3.2).

Barriers with any tensioning device e.g. bottom weight bar or tensioning device shall be tested with these, as part of the test specimen.

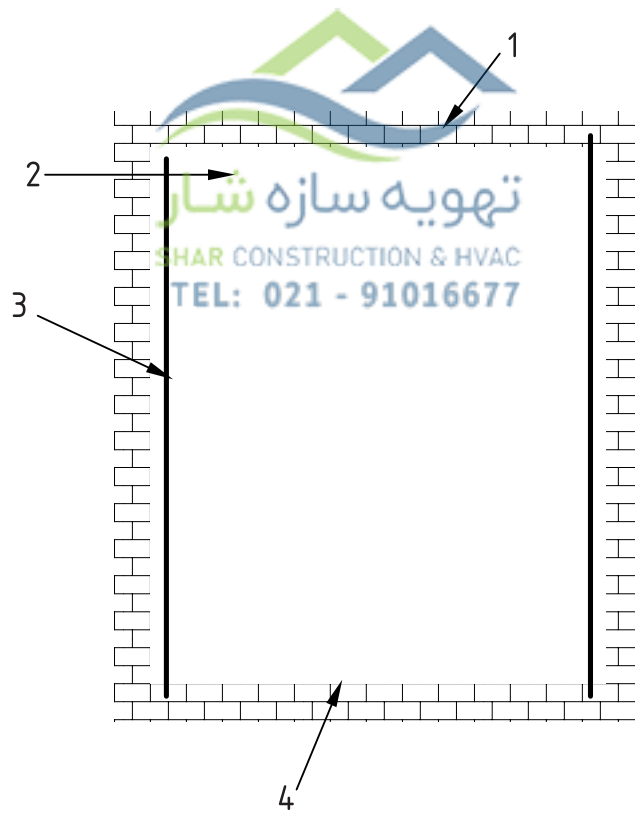
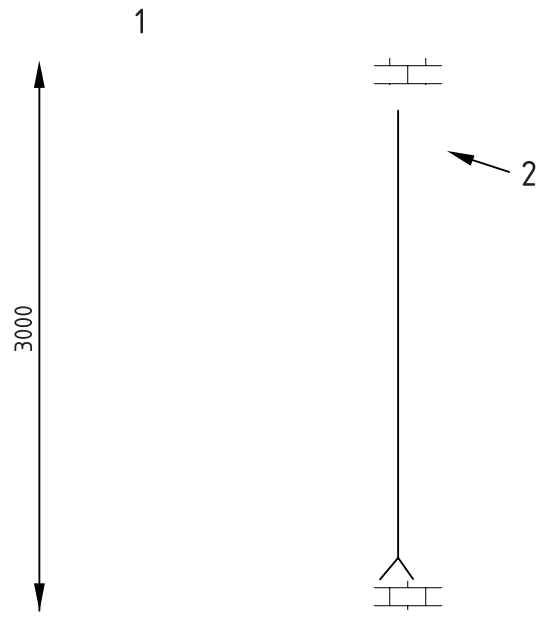

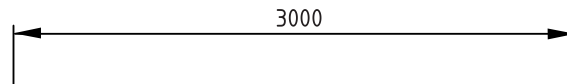

Key

- 1 Furnace
- 2 Head box
- 3 Side guides
- 4 Bottom bar

Figure D.1 — Head box and side guides installed within the opening of the furnace

D.2.4 Hems and joints

For materials that in normal use have hems or joints e.g. seams, welds or overlaps, the following shall be incorporated into the test:

- a) Barriers with horizontal joints shall be tested with a horizontal joint within 1 m of the barrier top.
- b) Barriers with a vertical joint shall be tested with at least one joint located 0,75 m to 1,25 m from a vertical side of the barrier.

Barriers that pass the test with horizontal joints will be deemed to satisfy the test with vertical joints, provided that vertical and horizontal joints have the same construction.

- c) Barriers with side hems shall be tested with at least one side hem.

TEL: 021 - 91016677

D.3 Installation of test specimen into the support frame

D.3.1 General

The test specimen shall be installed according to the manufacturer's instructions within the support frame using the chosen methods for attachment (see D.2.1).

D.3.2 Restraint

If the test specimen has no standard method of restraint e.g. side channels (unrestrained) at the barrier edge, the following shall apply:

- a) The specimen shall be installed so that the movement of the test specimen (e.g. the bottom bar towards and away from the furnace) is limited. The limiting method shall not apply additional loads (except those due to furnace pressure), nor assistance, to or from the specimen.
- b) Any gaps between the test specimen edge and the support frame shall be covered. The covering method shall not excessively restrain the test specimen edge (see Figure D.1).

NOTE Side covers/baffles installed into the support frame that overlap the test specimen unrestrained edge by a maximum of 200 mm is considered as an acceptable installation method (see Figure D.2).

D.3.3 Additional loads

Where appropriate (see D.2.2), additional load shall be applied to the bottom of the test specimen, so that the load experienced by the fixings (and material) reflects that of the tallest barrier in the family.

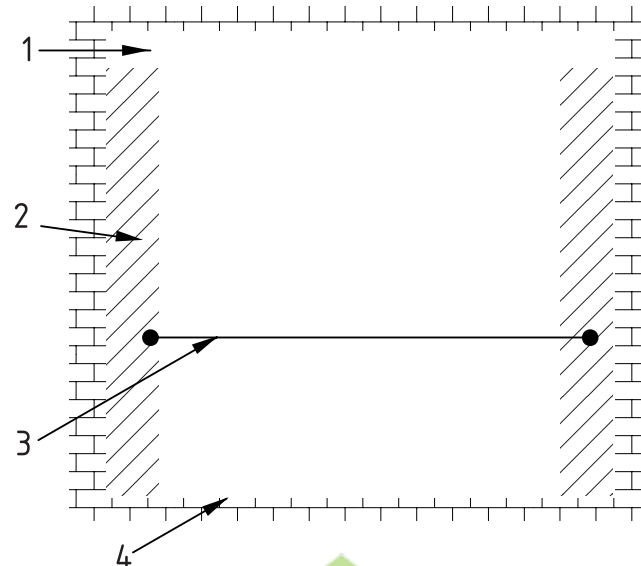

Key

- 1 Head box
- 2 Side baffles
- 3 Wire restraint
- 4 Bottom bar



Figure D.2 — Barrier with no side guides installed in the opening of the furnace with added side baffles to stop barrier movement during test

D.4 Test procedure

D.4.1 General

The testing shall be performed in accordance with EN 1363-1.

D.4.2 Furnace settings

The furnace shall be operated so that the neutral plane is 0,5 m above the bottom of the test specimen. The pressure at the top of the furnace shall not exceed 25 Pa.

D.4.3 D Classification

D.4.3.1 General

The furnace shall be operated following the standard heating curve defined in EN 1363-1.

Once the average temperature furnace has reached 620 °C (circa 6 min, 40 s) the average temperature shall be maintained at 620 °C.

NOTE This will ensure that the sample is subjected to a minimum furnace temperature of 600 °C.

D.4.3.2 Operating tolerances

The percentage deviation in the area of the curve of the average temperature recorded by the specified furnace thermocouples versus time from the area of the specified temperature/time curve shall be within:

- a) 15 %: for $5 < t < 10$ min;
- b) $15 - 0,5(t - 10)$ %: for $10 < t \leq 30$ min;
- c) $5 - 0,083(t - 30)$ %: for $30 \leq t < 60$ min;
- d) 2,5 %: for $t > 60$ min.

At any time after the first 10 min of test, the temperature recorded by any furnace thermocouple shall not normally differ from the specified average by more than 100 °C. Deviations from this requirement shall be considered acceptable if rapid burning occurs on the exposed surface of the test specimen, or if the barrier or edge seals are found to move during the test.

D.4.4 DH Classification

The furnace shall be operated following the standard heating curve defined in EN 1363-1.

The operating tolerances shall be as defined in EN 1363-2.

D.4.5 Time classes

Control the average furnace temperature for the required time, for each classification D, and DH. The five possible classes, corresponding to five required times, from the start of the test are as follows:

- a) 30 min,
- b) 60 min,
- c) 90 min,
- d) 120 min,
- e) 120 min plus.

At the end of the heating period switch off the furnace and allow the test specimen to cool to ambient.

D.5 Measurements and observations

D.5.1 Measurements

Furnace temperature and pressure measurements shall be made continuously and recorded at intervals of less than 1 min.

D.5.2 Integrity

Assessment of integrity failure of the test specimen (where the test specimen includes all details in D.2, but not gaps occurring between unrestrained edges and the support frame) shall be made:

- a) with gap gauges, against criteria given in EN 1363-1;
- b) with observations of sustained flaming against criteria given in EN 1363-1;
- c) with observations of collapse.

The time and nature of integrity failures shall be recorded.

D.5.3 General behaviour

The test specimen shall be continuously observed during the test, and after the test. Details and the time of any of the following occurrences shall be recorded in the test report:

- a) parts, components and flaming droplets falling from the test specimen;
- b) changes to the fixing methods;
- c) holes or cracks occurring in the test specimen.

D.6 Test report

The test report shall be written and information provided in accordance with the requirements of Annex A and EN 1363-1.



Annex E (informative)

Deflection of smoke barriers

E.1 General

This Annex shows how deflection can reduce the effectiveness of an active smoke barrier, a detailed explanation of the causes are given in E.2. The designer should be aware therefore of how active smoke barriers react to fire pressure from hot buoyant smoke that could make them unfit for purpose in a fire condition. Examples of deflection are shown in Figure E.1.



Figure E.1a - Curtain between columns - Enlarged gaps at sides and reduced effective smoke reservoir depth



Figure E.1b - Curtain between walls - No gaps at sides but reduced effective smoke layer depth caused by curtain lift

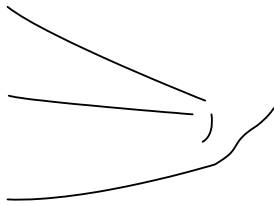
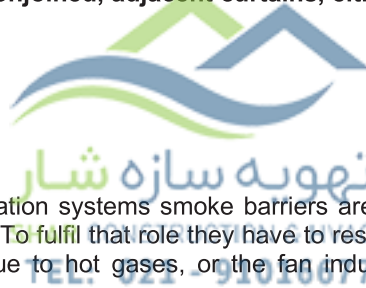

Figure E.1c - Curtain between columns – Enlarged gaps at sides and reduced effective smoke layer depth

Figure E.1d - Non conjoined, adjacent curtains, either in-line or angled



E.2 Principle

In smoke and heat exhaust ventilation systems smoke barriers are used to create reservoirs, which will contain smoke and hot gases. To fulfil that role they have to resist the sideways deflection caused by the buoyancy driven forces due to hot gases, or the fan induced forces in mechanical extract systems.

If they do not resist those forces, gaps might occur beneath the barrier or between the barrier and the building structure, leading to the flow of hot gases from the reservoir into adjacent areas.

Theoretical and experimental work has shown that the deflection of a smoke barrier and the flow of hot gases through gaps in it can be related to the hot gas layer contained by the barrier.

This Annex considers the deflection of free hanging active smoke barriers only, as those which are fixed at both ceiling and floor and/or sides are effectively locked in place and will not be subject to deflection. The method of calculation of the leakage through gaps in the barriers is valid for all types of barriers.

Free hanging active smoke barriers can be divided into two categories:

- those which act to contain a gas layer which does not extend below the bottom of the barrier (Figure E.2) (such as reservoir screens and channelling screens);
- those which fall to floor level and act to completely seal areas away from a smoke compartment in which the gas layer extends below the bottom of the barrier (Figure E.3) (such as might be installed along balconies to form a closed atrium).

The types will be referred to as those not reaching the floor and those closing an opening respectively.

The pressure of gases acting on it will cause the active smoke barrier to deflect from the normal vertically hanging position. This horizontal deflection of the barrier causes the bottom of the barrier to rise, which could lead to leakage of gas underneath the barrier if the rise takes the bottom of the barrier above the base of the gas layer. Because the barriers are not rigid, they are also likely to bow in use, like a sail in the wind. Such bowing will lead to a further rise of the bottom of the barrier.

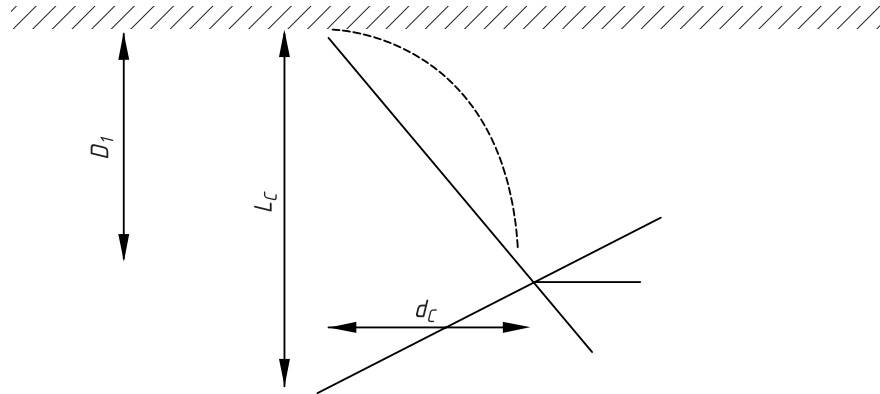

Key

- 1 Floor



Figure E.2 — Deflection of a smoke barrier which does not reach the floor

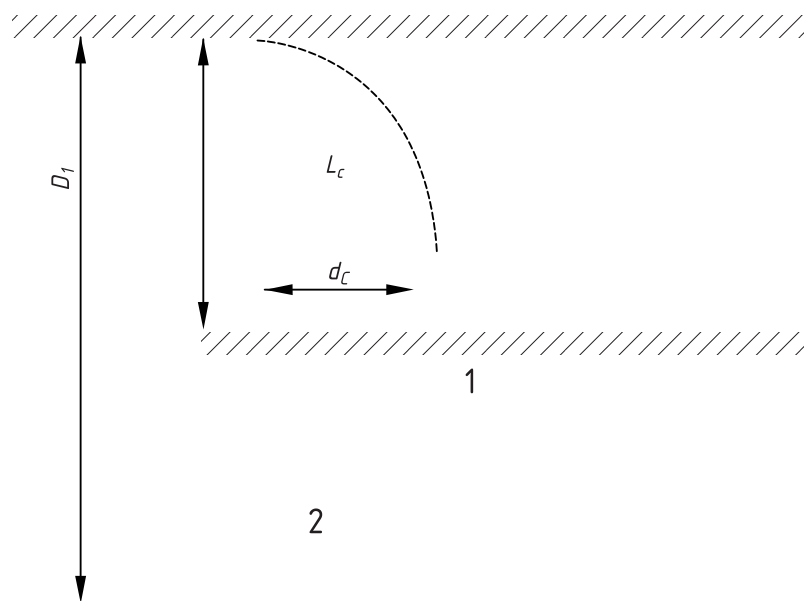

Key

- 1 Floor
- 2 Window



Figure E.3 — Deflection of a smoke barrier closing an opening

E.3 Barriers not reaching the floor

The deflection of the barrier is calculated from (see also Figure E.2)

$$d_c = 1,2 \frac{\rho_o \theta_l D_l^3}{3T_1 (2M_b + M_c L_c)} \quad (\text{E.1})$$

where

- d_c = Deflection of the barrier (m)
- ρ_o = Density of ambient air (kg/m^3)
- θ_l = Temperature rise above ambient of the gases in the smoke layer ($^{\circ}\text{C}$)
- D_l = Depth of the gas layer (m)
- T_1 = Absolute temperature of gas layer in a reservoir (K)
- M_b = Mass per metre length of the barrier's bottom bar (kg/m)
- M_c = Mass per m^2 of the barrier fabric (kg/m^2)
- L_c = Length of the smoke barrier from top to bottom bar, measured along the fabric (m)

The length of the barrier to contain a gas layer of depth D_1 is calculated using an iterative procedure from

$$L_c = D_1 + d_c \tan \left[\frac{\tan^{-1} \left(\frac{d_c}{D_1} \right)}{2} \right] \quad (\text{E.2})$$

The procedure is:

- 1 Assume a starting value for $L_c \geq D_1$
- 2 Calculate d_c using Equation (E.1)
- 3 Calculate next value of L_c using Equation (E.2)

Repeat steps 1 to 3 with the new value of L_c , until successive values of L_c differ by 1 % or less.

The calculated value for L_c should then be modified by including a term to allow for bowing of the barrier, so that

$$L_{c(\text{final})} = L_c + 1,7(L_c - D_1) \quad (\text{E.3})$$

E.4 Barriers closing an opening

The deflection of the barrier is calculated from (see Figure E.3)

$$d_c = 1,2 \frac{\rho_0 \theta (3D_1 - 2d_0) d_0^2}{3T_1 (2M_b + M_c L_c)} \quad (\text{E.4})$$

where d_0 is the height of the opening (m) and other variables are as defined above.

The required barrier length to contain a gas layer of depth D_1 is calculated using an iterative procedure from

$$L_c = d_0 + d_c \tan \left[\frac{\tan^{-1} \left(\frac{d_c}{d_0} \right)}{2} \right] \quad (\text{E.5})$$

The procedure is:

- 1 Assume a value for $L_c \geq d_0$
- 2 Calculate d_c using Equation (E.4)
- 3 Calculate L_c using Equation (E.5)

Repeat steps 1 to 3 with the new value of L_c , until successive values of L_c differ by 1 % or less.

The calculated value for L_c should then be modified by including a term to allow for bowing of the barrier as for barriers not reaching the floor, so that

$$L_{c(\text{final})} = L_c + 1,7(L_c - d_0) \quad (\text{E.6})$$

E.5 Smoke leakage through gaps in barriers

The leakage of smoke and hot gas through vertical gaps at the edges of smoke barriers can be related to the hot gas layer that they contain by the following equation

$$M_g = \frac{2A_g}{3} \left(\frac{352,17}{T_1} \right) \left(\frac{2gD_1\theta_1}{T_0} \right)^{1/2} \quad (\text{E.7})$$

where

- M_g = Mass of gas flowing through the gap (kg/s)
- A_g = Area of the gap (m²)
- T_1 = Absolute temperature of the gases in the layer (K)
- T_0 = Absolute ambient temperature (K)
- D_1 = Depth of gas in reservoir (m)
- g = Acceleration due to gravity (m/s²)
- θ_1 = Temperature rise above ambient of the gas (°C)

The gases flowing through barrier gaps will entrain air as they rise to the ceiling, and can cause the formation of a smoky gas layer within the area which the barriers are intended to protect. Such a gas layer will be considerably cooler than that within the main reservoir. Where a smoke layer forms within the area intended to be protected by the smoke barriers, then it can be necessary to consider further measures to protect occupants. Such entrainment has not been closely studied, but preliminary research suggests that the mass entrained can be related to the mass flowing through the gaps to give a conservative estimate of the smoke rising to the ceiling, using:

$$M_p = 6M_g h_p \quad (\text{E.8})$$

where

- M_p = Mass of gas flowing into gas layer in protected area (kg/s)
- M_g = Mass of gas flowing through a gap in a smoke barrier (kg/s)
- h_p = Height of rise from the base of the hot gas layer in the reservoir to the ceiling in the protected area.

NOTE This equation is derived from a small number of experiments. It is desirable to extend the study further to confirm the derived correlation.

A calculation procedure will be:

The temperature of the gas layer within the protected area is:

$$\theta_p = \frac{M_g \theta_1}{M_p} \quad (\text{E.9})$$

where

- θ_p = Temperature above ambient of the smoke layer initially forming (ignoring any subsequent cooling) in the protected reservoir adjacent to the leakage (°C).

Annex ZA (informative)

Clauses of this European Standard addressing the provisions of the EU Construction Products Directive

ZA.0 Scope of this annex

The scope as given in Clause 1 is applicable.

ZA.1 Relationship between EU Directive and this European Standard

This European Standard has been prepared under a Mandate given to CEN by the European Commission and the European Free Trade Association.

The clauses of this European Standard shown in this annex meet the requirements of the Mandate given under the EU Construction Products Directive (89/106/EEC).

Compliance with these clauses confers a presumption of fitness of the construction products covered by this European Standard for their intended use.

WARNING — Other requirements and other EU Directives, not affecting the fitness for intended use may be applicable to a construction product falling within the scope of this European Standard.

NOTE In addition to any specific clauses relating to dangerous substances contained in this standard, there may be other requirements applicable to the products falling within its scope (e.g. transposed European legislation and national laws, regulations and administrative provisions). In order to meet the provisions of the EU Construction Products Directive, these requirements need also to be complied with, when and where they apply. (An informative database of European and national provisions on dangerous substances is available at the Construction web site on EUROPA (CREATE, accessed through <http://europa.eu.int/comm/enterprise/construction/internal/dangsub/dangmain.htm>)).

Construction Product : Smoke barriers

Intended uses : Smoke barriers for smoke control n construction works in industrial and commercial locations.

Table ZA.1 — Relevant Clauses

| Essential characteristics | Clauses in this European Standard | Mandated levels and/or classes | Notes |
|--|-----------------------------------|--------------------------------|-------|
| Operational reliability | 5.3 | - | - |
| Response delay | 5.4 | - | - |
| Deployment safety | 5.4 | - | - |
| Fire Resistance - Smoke leakage | 5.5 | - | - |
| Fire Resistance - Mechanical stability | 5.2 | D or DH | - |
| Fire resistance – Integrity | 5.2 | D or DH | |

ZA.2 Procedure for the attestation of conformity of smoke barriers

Smoke barriers for the intended use listed shall follow the system of attestation of conformity shown in Table ZA.2.

Table ZA.2 — Attestation of conformity system

| Product | Intended use | Level(s) or class(es) | Attestation of conformity system |
|--|--------------|-----------------------|----------------------------------|
| Smoke barriers | Fire safety | D or DH | 1 |
| System 1: See Construction Products Directive Annex III.2.(i), without audit testing of samples. | | | |

The product certification body will certify the initial type testing of all characteristics given in Table ZA.1, in accordance with the provisions of 6.2, and for the initial inspection of the factory and of the factory production control, and for the continuous surveillance, assessment and approval of the factory production control, all characteristics in Table ZA.1 shall be of interest to the approved body (see annex A). The manufacturer shall operate a factory production control system in accordance with the provisions of 6.3.

ZA.3 CE marking

The manufacturer or his authorised representative established within the EEA is responsible for the affixing of the CE marking. The CE marking symbol in the format specified in the EU Directive 93/68/EC shall be shown on the product. In addition, the CE marking symbol shall appear on the packaging and/or on the accompanying commercial documents, together with the following information:

- identification number of the certification body, and
- the last two digits of the year in which the marking was affixed, and
- the appropriate number of the EC-certificate of conformity, and
- the number of this standard (EN 12101-1), and
- the product, i.e. static smoke barrier; active smoke barrier, and
- the application type i.e. ASB1; ASB2; ASB3 or ASB4 as shown in 4.2, and
- the fire resistance classification (D or DH), and
- the response delay (active barriers only), and
- A_1 — the openings, gaps and free area (see 5.5.3), and
- the maximum material permeability (if less than $25 \text{ m}^3/\text{h}$) including the temperature at which the test was conducted (e.g. ambient and/or $200 \text{ }^\circ\text{C}$) in accordance with EN 1634-3 (see 5.5.5). A_1

Figure ZA.1 gives an example of the information to be given on the accompanying commercial documents.

| | |
|--|-----------------------|
|  | |
| 0123 | |
| Any Co Ltd, P.O. Box 21, B - 1050 | |
| 06 | |
| 0123-CPD-001 | |
| EN 12101-1 | |
| Active smoke barrier, type ASB2 | |
| Resistance to fire classification | - DH 30 |
| Response delay | - 60 s |
| Openings, gaps and perimeter spaces: | |
| Gap _{head} (a to f) | 5 mm |
| Gap _{edge} (g) | 19 mm |
| Gap _{joint} (h) | 0 mm |
| Area _{head} = W x Gap _{head} | 25000 mm ² |
| Area _{edge} = D x Gap _{edge} | 38000 mm ² |
| Area _{joint} = D x Gap _{joint} | 0 mm ² |
| Area _{total} = N ₁ · Area _{head} + N ₂ · Area _{edge} + N ₃ · Area _{joint} | |
| Maximum barrier permeability | 20 m ³ /h |
| tested at ambient temperature | |

Figure ZA.1 — Example CE marking information

In addition to any specific information relating to dangerous substances shown above, the product should also be accompanied, when and where required and in the appropriate form, by documentation listing any other legislation on dangerous substances for which compliance is claimed, together with any information required by that legislation.

NOTE European legislation without national derogations need not be mentioned.

ZA.4 Certificate and declaration of conformity

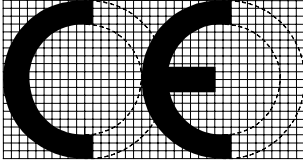
When compliance with the conditions of this annex is achieved, the certification body shall draw up a certificate of conformity (EC Certificate of conformity), which entitles the manufacturer to affix the CE marking. The certificate shall include:

- name, address and identification number of the certification body;
- name and address of the manufacturer, or his authorised representative established in the EEA, and place of production;
- description of the product (type, identification, use, ...);

- provisions to which the product conforms (i.e. annex ZA of this EN);
- particular conditions applicable to the use of the product (e.g. provisions for use under certain conditions);
- the number of the certificate;
- conditions and period of validity of the certificate, where applicable;
- name of, and position held by, the person empowered to sign the certificate.

In addition, the manufacturer shall draw up a declaration of conformity (EC Declaration of conformity) including the following:

- name and address of the manufacturer, or his authorised representative established in the EEA;
- name and address of the certification body;
- description of the product (type, identification, use, ...), and a copy of the information accompanying the CE marking;
- provisions to which the product conforms (i.e. annex ZA of this EN);
- particular conditions applicable to the use of the product (e.g. provisions for use under certain conditions);
- number of the accompanying EC Certificate of conformity;
- name of, and position held by, the person empowered to sign the declaration on behalf of the manufacturer or of his authorised representative.

The declaration and certificate shall be presented in the language(s) of the Member State of use of the product.

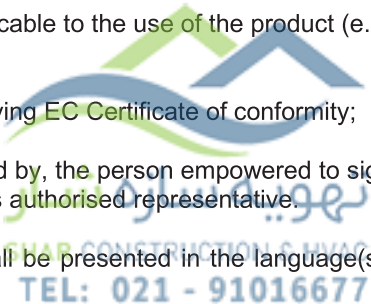

Bibliography

- [1] EN 45011, *General requirements for bodies operating product certification systems (ISO/IEC Guide 65:1996)*.
- [2] EN ISO/IEC 17025, *General requirements for the competence of testing and calibration laboratories (ISO/IEC 17025:1999)*.
- [3] ISO 3864-1, *Graphic symbols - Safety colours and safety signs – Part:1: Design principles for safety signs in workplaces and public areas*.
- [4] EU Directive 93/68/EC, COUNCIL DIRECTIVE 93/68/EEC of 22 July 1993 amending Directives 87/404/EEC (simple pressure vessels), 88/378/EEC (safety of toys), 89/106/EEC (construction products), 89/336/EEC (electromagnetic compatibility), 89/392/EEC (machinery), 89/686/EEC (personal protective equipment), 90/384/EEC (non-automatic weighing instruments), 90/385/EEC (active implantable medicinal devices), 90/396/EEC (appliances burning gaseous fuels), 91/263/EEC (telecommunications terminal equipment), 92/42/EEC (new hot-water boilers fired with liquid or gaseous fuels) and 73/23/EEC (electrical equipment designed for use within certain voltage limits).
- [5] EN 12101–2, *Smoke and heat control systems — Part 2: Specification for natural smoke and heat exhaust ventilators*.
- [6] EN 12101–3 *Smoke and heat control systems — Part 3: Specification for powered smoke and heat exhaust ventilators*.
- [7] prEN 13501–3, *Fire classification of construction products and building elements — Part 3: Classification using data from fire resistance tests on products and elements used in building service installations: fire resisting ducts and fire dampers*.

SHAR CONSTRUCTION & HVAC
TEL: 021 - 91016677

BSI - British Standards Institution

BSI is the independent national body responsible for preparing British Standards. It presents the UK view on standards in Europe and at the international level. It is incorporated by Royal Charter.

Revisions

British Standards are updated by amendment or revision. Users of British Standards should make sure that they possess the latest amendments or editions.

It is the constant aim of BSI to improve the quality of our products and services. We would be grateful if anyone finding an inaccuracy or ambiguity while using this British Standard would inform the Secretary of the technical committee responsible, the identity of which can be found on the inside front cover. Tel: +44 (0)20 8996 9000. Fax: +44 (0)20 8996 7400.

BSI offers members an individual updating service called PLUS which ensures that subscribers automatically receive the latest editions of standards.

Buying standards

Orders for all BSI, international and foreign standards publications should be addressed to Customer Services. Tel: +44 (0)20 8996 9001. Fax: +44 (0)20 8996 7001 Email: orders@bsigroup.com You may also buy directly using a debit/credit card from the BSI Shop on the Website <http://www.bsigroup.com/shop>

In response to orders for international standards, it is BSI policy to supply the BSI implementation of those that have been published as British Standards, unless otherwise requested.

Information on standards

BSI provides a wide range of information on national, European and international standards through its Library and its Technical Help to Exporters Service. Various BSI electronic information services are also available which give details on all its products and services. Contact Information Centre. Tel: +44 (0)20 8996 7111 Fax: +44 (0)20 8996 7048 Email: info@bsigroup.com

Subscribing members of BSI are kept up to date with standards developments and receive substantial discounts on the purchase price of standards. For details of these and other benefits contact Membership Administration. Tel: +44 (0)20 8996 7002 Fax: +44 (0)20 8996 7001 Email: membership@bsigroup.com

Information regarding online access to British Standards via British Standards Online can be found at <http://www.bsigroup.com/BSOL>

Further information about BSI is available on the BSI website at <http://www.bsigroup.com>.

Copyright

Copyright subsists in all BSI publications. BSI also holds the copyright, in the UK, of the publications of the international standardization bodies. Except as permitted under the Copyright, Designs and Patents Act 1988 no extract may be reproduced, stored in a retrieval system or transmitted in any form or by any means – electronic, photocopying, recording or otherwise – without prior written permission from BSI.

This does not preclude the free use, in the course of implementing the standard, of necessary details such as symbols, and size, type or grade designations. If these details are to be used for any other purpose than implementation then the prior written permission of BSI must be obtained.

Details and advice can be obtained from the Copyright and Licensing Manager. Tel: +44 (0)20 8996 7070 Email: copyright@bsigroup.com