

Smoke and heat control systems —

Part 6: Specification for pressure differential systems — Kits



The European Standard EN 12101-6:2005 has the status of a
British Standard

ICS 13.220.99

National foreword

This British Standard was published by BSI. It is the UK implementation of EN 12101-6:2005, incorporating corrigendum August 2006. It supersedes BS 5588-4:1998 which is withdrawn.

The UK participation in its preparation was entrusted to Technical Committee FSH/25, Smoke and heat control systems.

A list of organizations represented on FSH/25 can be obtained on request to its secretary.

This publication does not purport to include all the necessary provisions of a contract. Users are responsible for its correct application.

Compliance with a British Standard cannot confer immunity from legal obligations.



This British Standard was published under the authority of the Standards Policy and Strategy Committee on 30 June 2005

© BSI 2006

ISBN 0 580 46255 2

Amendments issued since publication

Amd. No.	Date	Comments
16745 Corrigendum No. 1	30 November 2006	Replacement of Equations A.3, A.3a, A.10, A.12 and A.25

English version

Smoke and heat control systems - Part 6: Specification for pressure differential systems - Kits

Systèmes pour le contrôle des fumées et de la chaleur -
Partie 6: Spécifications pour les systèmes à différentiel de
pression - Kits

Anlagen zur Kontrolle von Rauch- und Wärmeströmungen
- Teil 6: Anforderung an Differenzdrucksysteme - Bausätze

This European Standard was approved by CEN on 17 January 2005.

CEN members are bound to comply with the CEN/CENELEC Internal Regulations which stipulate the conditions for giving this European Standard the status of a national standard without any alteration. Up-to-date lists and bibliographical references concerning such national standards may be obtained on application to the Central Secretariat or to any CEN member.

This European Standard exists in three official versions (English, French, German). A version in any other language made by translation under the responsibility of a CEN member into its own language and notified to the Central Secretariat has the same status as the official versions.

CEN members are the national standards bodies of Austria, Belgium, Cyprus, Czech Republic, Denmark, Estonia, Finland, France, Germany, Greece, Hungary, Iceland, Ireland, Italy, Latvia, Lithuania, Luxembourg, Malta, Netherlands, Norway, Poland, Portugal, Slovakia, Slovenia, Spain, Sweden, Switzerland and United Kingdom.



EUROPEAN COMMITTEE FOR STANDARDIZATION
COMITÉ EUROPÉEN DE NORMALISATION
EUROPÄISCHES KOMITEE FÜR NORMUNG

Management Centre: rue de Stassart, 36 B-1050 Brussels

Contents

Page

Foreword	3
0 Introduction	4
1 Scope	9
2 Normative references	9
3 Terms, definitions, symbols and units	10
4 System classification for buildings	15
5 Features of a pressurization system	31
6 Spaces to be pressurized	39
7 Design procedures for pressurization systems	49
8 Pressurization of refuges and other spaces	55
9 Depressurization	55
10 Interaction with other fire protection systems and other building systems.....	59
11 Installation and equipment (including components).....	61
12 Acceptance testing	70
13 Maintenance	71
14 Documentation	73
15 Design calculations	74
16 Evaluation of conformity	75
Annex A (informative) Design recommendations	80
Annex B (informative) Solutions for inability to obtain design pressure differential	92
Annex ZA (informative) Clauses of this European Standard addressing essential requirements or other provisions of the Construction Products Directive	93
Bibliography.....	98

Foreword

This document (EN 12101-6:2005) has been prepared by Technical Committee CEN/TC 191 "Fixed firefighting systems", the secretariat of which is held by BSI.

This European Standard shall be given the status of a national standard, either by publication of an identical text or by endorsement, at the latest by December 2005, and conflicting national standards shall be withdrawn at the latest by December 2005.

This document has been prepared under a mandate given to CEN by the European Commission and the European Free Trade Association, and supports essential requirements of EU Directive 89/106/EEC.

For relationship with EU Directive(s), see informative Annex ZA which is an integral part of this document.

This European Standard has the general title "*Smoke and heat control systems*" and consists of the following eleven parts:

Part 1: *Specification for smoke barriers;*

Part 2: *Specification for natural smoke and heat exhaust ventilators;*

Part 3: *Specification for powered smoke and heat exhaust ventilators;*

Part 4: *Fire and smoke control installations – Kits;*

Part 5: *Design and calculation for smoke and exhaust ventilation systems (published as CR 12101-5);*

Part 6: *Specification for pressure differential systems – Kits;*

Part 7: *Smoke control ducts;*

Part 8: *Specification for smoke control dampers;*

Part 9: *Control panels and emergency control panels;*

Part 10: *Power supplies;*

EN 12101 is included in a series of European Standards planned to cover also:

- a) Gas extinguishing systems (EN 12094 and EN ISO 14520);
- b) Sprinkler systems (EN 12259);
- c) Powder systems (EN 12416);
- d) Explosion protection systems (EN 26184);
- e) Foam systems (EN 13565);
- g) Hose reel systems (EN 671);
- h) Water spray systems (EN 14816).

According to the CEN/CENELEC Internal Regulations, the national standards organizations of the following countries are bound to implement this European Standard: Austria, Belgium, Cyprus, Czech Republic, Denmark, Estonia, Finland, France, Germany, Greece, Hungary, Iceland, Ireland, Italy, Latvia, Lithuania, Luxembourg, Malta, Netherlands, Norway, Poland, Portugal, Slovakia, Slovenia, Spain, Sweden, Switzerland and United Kingdom.

0 Introduction

0.1 Smoke movement in the building

This document covers information and requirements on the design, calculation methods, installation and testing of systems intended to limit the spread of smoke by means of pressure differentials.

Pressure differential systems can be achieved by two methods:

- i) pressurization – maintaining a positive pressure within the protected spaces (see Figure 1a), or
- ii) depressurization – removing hot gases from the fire zone at a lower pressure than the adjacent protected space (see Figure 1b).



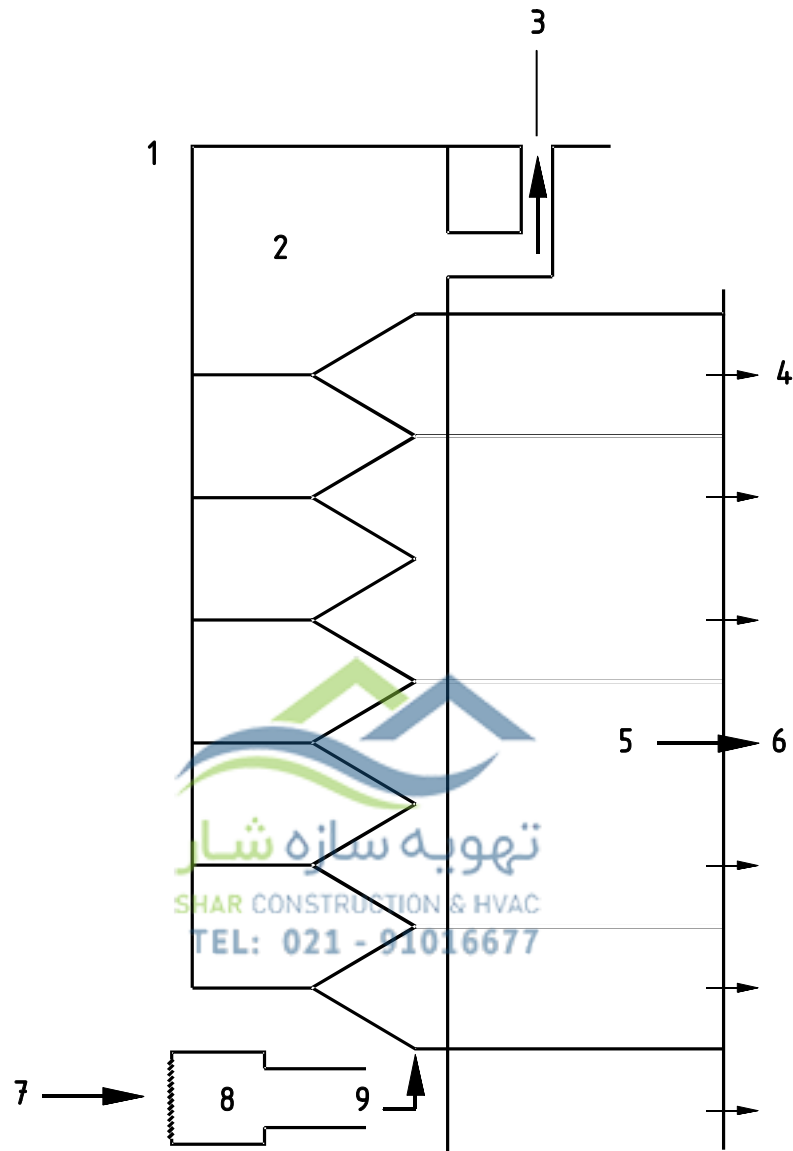

Key

- 1 Outside
- 2 Pressurized space
- 3 Overpressure relief
- 4 External leakage
- 5 Fire zone
- 6 Air release vents
- 7 Air intake
- 8 Supply fan
- 9 Supply ductwork

Figure 1 a) — Examples of pressurization and depressurization systems

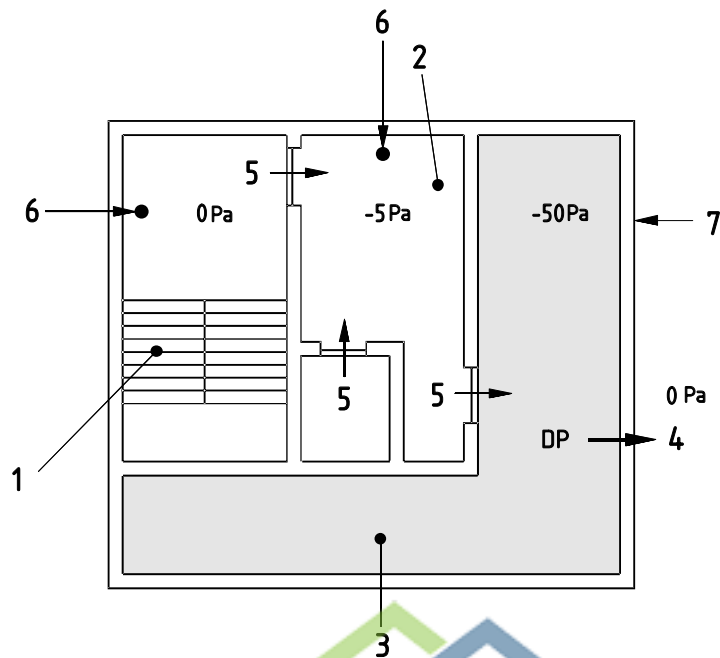

Key

- 1 Stair
- 2 Lobby
- 3 Accommodation (DP Depressurized space)
- 4 Exhaust (Depressurize)
- 5 Leakage path through doors etc.
- 6 Replacement air
- 7 Fire-resisting construction

Figure 1 b) — Example of a depressurization system – basements or other spaces with no external windows

In the event of fire, the smoke produced follows a pattern of movement arising from the following main driving forces.

Buoyancy experienced by hot gases on the fire storey. Within the fire zone, smoke produced by the fire experiences a buoyancy force owing to its reduced density. In a building this can result in upwards smoke movement between storeys if leakage paths exist to the storey above. In addition, this buoyancy can cause smoke to spread through leakage paths in vertical barriers between rooms, e.g. doors, walls, partitions. The pressure differential typically causes smoke and hot gases to leak out of gaps at the top of a door and cool air to be drawn in through gaps at the bottom.

Thermal expansion of hot gases in the fire zone. Fire induced expansion of gases can result in a build up of pressure, accompanied by a flow of hot gases out of the compartment. However, in most cases the initial expansion forces may dissipate quickly and may be ignored.

Stack effect throughout the building. In cold ambient conditions, the air in a building is generally warmer and less dense than the external air. The buoyancy of the warm air causes it to rise within vertical shafts in the

building, and a pressure gradient is set up in the column such that cold air is drawn into the bottom of the shaft and warm air is forced out at the top. In warm ambient conditions, when the air inside the building can be cooler than that outside, the reverse condition may exist, i.e. air is forced out at the bottom of the stack and drawn in at the top. In either case, at some intermediate point a neutral pressure plane is formed where the pressures of the external and the internal air are equal.

Wind pressure forces. When wind blows towards the side of a building, it is slowed down, resulting in a build-up of pressure on the windward face. At the same time the wind is deflected and accelerated around the side walls and over the roof, creating a reduction in pressure on the leeward side of the building, i.e. suction in these areas. The greater the speed of the wind, the greater the suction. The main effect of these pressures is to produce a horizontal movement of air through the building from the windward to the leeward sides. If the building envelope is leaky, e.g. with openable doors and windows, then the effect will be more pronounced. In a fire, if a broken window exists on the windward side of the building, the wind can force the smoke through the building horizontally or in some circumstances vertically. It can be difficult to predict accurately the wind pressures that will be exerted on buildings or the resultant internal airflows, and computer or wind tunnel analysis may be necessary for a full understanding.

NOTE Guidance on wind loading is given in prEN 1991-2-4.

HVAC systems. HVAC systems can supply air to the fire zone and aid combustion, or transport smoke rapidly to areas not within the zone of the source of the fire, and are often shut down in the event of fire. However, such systems can often be modified to assist in restricting smoke spread or be used in conjunction with pressure differential system air supply and/or release systems.

0.2 Objectives of pressure differential systems

The objective of this document is to give information on the procedures intended to limit the spread of smoke from one space within a building to another, via leakage paths through physical barriers (e.g. cracks around closed doors) or open doors.

Pressure differential systems offer the facility of maintaining tenable conditions in protected spaces, for example escape routes, firefighting access routes, firefighting shafts, lobbies, staircases, and other areas that require to be kept free of smoke. This document offers information with regard to life safety, firefighting and property protection within all types of buildings. It is necessary to determine not only where the fresh air supply for pressurization is to be introduced into a building but also where that air and smoke will leave the building and what paths it will follow in the process. Similar considerations apply to depressurization schemes, i.e. the route for the exhaust air, plus consideration for the inlet replacement air and the paths it will follow.

The aim therefore is to establish a pressure gradient (and thus an airflow pattern) with the protected escape space at the highest pressure and the pressure progressively decreasing in areas away from the escape routes.

Pressure differential systems provide one means of improving the level of fire safety within a building. A decision as to whether such a system is appropriate to a particular project should be taken in context with the overall design strategy for means of escape, firefighting and property protection within the building. This will lead to design assumptions which are expected to be appropriate to the particular project, especially in regard of the most likely leakage paths caused by simultaneous open doors as outlined in Clause 5.

Drawings that accompany the text in this document are intended only to clarify points made in the text. It should be assumed that the arrangements shown are informative only.

When the designer is unable to comply with this document in full, an alternative fire safety engineered approach can be adopted. The engineered solution should adopt the functional requirements set out in this document wherever appropriate.

0.3 Smoke control methods

The effect of the air movement forces described above is to create pressure differentials across the partitions, walls and floors which can add together and can cause smoke to spread to areas removed from the fire source. The techniques most commonly used to limit the degree of smoke spread, or to control its effects, are:

EN 12101-6:2005 (E)

- a) smoke containment using a system of physical barriers to inhibit the spread of smoky gases from the fire affected space to other parts of the building, e.g. walls and doors;
- b) smoke clearance, using any method of assisting the fire service in removing smoky gases from a building when smoke is no longer being produced, i.e. post extinction;
- c) smoke dilution, deliberately mixing the smoky gases with sufficient clean air to reduce the hazard potential;
- d) smoke (and heat) exhaust ventilation, achieving a stable separation between the warm smoky gases forming a layer under the ceiling, and those lower parts of the same space requiring protection from the effects of smoke for evacuation of occupants and firefighting operations. This normally requires the continuous exhaust of smoke using either natural or powered ventilators, and the introduction of clean replacement air into the fire affected space beneath the smoke layer;
- e) pressurization, see 3.1.27;
- f) depressurization, see 3.1.10.

This document provides guidance and information on smoke control using pressure differentials, i.e. only the techniques given in items e) and f).

Items a) - d) are not discussed further within this document.

Smoke control using pressure differentials generally requires lower ventilation rates than b) or c) above but is limited to the protection of enclosed spaces adjacent to spaces being smoke logged in the event of a fire.

0.4 Analysis of the problem

The purpose of a pressure differential system, whether used for the protection of means of escape, firefighting operations or property protection, can have a significant influence on the system design and specification. It is, therefore, essential that the fire safety objectives are clearly established and agreed with the appropriate authorities at an early stage in the design process.

The acceptability of any system ultimately depends upon whether the necessary pressure differential levels and the airflow rates are achieved. Guidance on the means of calculating the air supply rates to achieve these levels are given within this document. However, providing that the functional objectives of the systems (see subclauses a), b) and c) below) are met then the designer may choose to use other calculation procedures, as appropriate, in substantiation of their design.

The objectives addressed in this document are as follows:

- a) **Life safety.** It is essential that tenable conditions for life safety are maintained in protected spaces for as long as they are likely to be in use by the building occupants.
- b) **Dedicated firefighting routes.** To enable firefighting operations to proceed efficiently, protected firefighting access routes (e.g. firefighting shafts) should be maintained essentially free of smoke so that access to the fire affected storey can be achieved without the use of breathing apparatus. The pressure differential system should be designed so as to limit the spread of smoke into the dedicated firefighting route under normal firefighting conditions.
- c) **Property protection.** The spread of smoke should be prevented from entering into sensitive areas such as those containing valuable equipment, data processing and other items that are particularly sensitive to smoke damage.

1 Scope

This document specifies pressure differential systems designed to hold back smoke at a leaky physical barrier in a building, such as a door (either open or closed) or other similarly restricted openings. It covers methods for calculating the parameters of pressure differential smoke control systems as part of the design procedure. It gives test procedures for the systems used, as well as describing relevant, and critical, features of the installation and commissioning procedures needed to implement the calculated design in a building. It covers systems intended to protect means of escape such as stairwells, corridors and lobbies, as well as systems intended to provide a protected firefighting bridgehead for the Fire Services.

The systems incorporate smoke control components in accordance with the relevant Parts of EN 12101 and kits comprising these and possibly other components (see 3.1.18). This document gives requirements and methods for the evaluation of conformity for such kits.

2 Normative references

The following referenced documents are indispensable for the application of this document. For dated references, only the edition cited applies. For undated references, the latest edition of the referenced document (including any amendments) applies.

EN 1505, *Ventilation for buildings — Sheet metal air ducts and fittings with rectangular cross section — Dimensions*

EN 1506, *Ventilation for buildings — Sheet metal air ducts and fittings with circular cross section — Dimensions*

prEN 12101-4, *Smoke and heat control systems — Part 4: Fire and smoke installations — Kits*

prEN 12101-7, *Smoke and heat control systems — Part 7: Smoke control ducts*

prEN 12101-9, *Smoke and heat control systems — Part 9: Control panels*

prEN 12101-10, *Smoke and heat control systems — Part 10: Power supplies*

prEN 13501-3, *Fire classification of construction products and building elements — Part 3: Classification using data from fire resistance tests on products and elements used in building service installations: fire resisting ducts and fire dampers*

prEN 13501-4, *Fire classification of construction products and building elements — Part 4: Classification using data from fire resistance tests on components of smoke control systems*

EN ISO 9001:2000, *Quality management systems — Requirements (ISO 9001:2000)*

EN ISO 13943:2000, *Fire safety — Vocabulary (ISO 13943:2000)*

3 Terms, definitions, symbols and units

3.1 General terms and definitions

For the purposes of this document, the terms and definitions given in EN ISO 13943:2000 and the following apply.

3.1.1

accommodation

any part of the construction works which is not directly pressurized and does not form part of a protected escape route or firefighting shaft

3.1.2

air inlet

connection to outside air to allow the entry of air from outside the construction works

3.1.3

air release

means by which pressurizing air is able to escape from the accommodation or other unpressurized space to outside the building

3.1.4

atrium (plural atria)

enclosed space, not necessarily vertically aligned, passing through two or more storeys in a construction works

NOTE Lift wells, escalator shafts, building services ducts, and protected stairways are not classified as atria.

3.1.5

authorities

organisations, officers or individuals responsible for approving SHEVS, pressure differential and sprinkler systems as appropriate, equipment and procedures, e.g. the fire and building control authorities, the fire insurers, or other appropriate public authorities

3.1.6

circulation space

space mainly used as a means of access between a room and an exit from the building or compartment

3.1.7

commissioning

act of ensuring that all components, kits and the system are installed and operating in accordance with the manufacturer's instructions and this document

3.1.8

control panel

device containing control and/or release devices, manual and/or automatic, used to operate the system

3.1.9

Defend in Place

means of escape design criterion in flats and maisonettes based on operational firefighting tactics where, owing to the high degree of compartmentation provided, the spread of fire from one dwelling to another is unusual. It is therefore not assumed in the event of a fire that it is necessary to evacuate the whole building, whole floors or even dwellings adjacent to the fire

3.1.10

depressurization

smoke control using pressure differentials where the air pressure in the fire zone or adjacent spaces is reduced below that in the protected space

3.1.11

depressurized space

fire compartment from which air and smoke are exhausted for the purposes of depressurization

3.1.12

firefighting lift

lift designed to have additional protection, with controls that enable it to be used under the direct control of the fire service in fighting a fire

3.1.13

firefighting lobby

protected lobby providing access from firefighting stair to accommodation area and to any associated firefighting lift

3.1.14

firefighting shaft

protected enclosure containing a firefighting stair, firefighting lobbies and, if provided, a firefighting lift, together with its machine room

3.1.15

firefighting stair

protected stairway communicating with the accommodation area only through a firefighting lobby

3.1.16

fire zone

room or compartment in which the fire is assumed to occur for the purposes of design

3.1.17

fully-involved fires

another term for fully-developed fires, which is the state of total involvement of combustible materials, within an enclosure, in a fire

3.1.18

kit

set of at least two separate components that need to be put together to be installed permanently in the works to become an assembled system. The kit needs to be placed on the market allowing a purchaser to buy it in a single transaction from a single supplier. The kit may include all, or only a subset of, the components necessary to form a complete pressure differential system

3.1.19

leakage paths

gaps or cracks in the construction or around doors and windows which provide a path for air to flow between the pressurized/depressurized space and the exterior of the building or the construction works

3.1.20

life safety systems

systems that need to remain operational for a specific period of time, where the occupant of the premises need to be alerted to a fire situation, and then be able to exit the premises in the time period calculated, with the systems maintaining operational status for the means of escape situation. These systems would include fire protection systems, control systems for smoke ventilation and pressure differential systems



EN 12101-6:2005 (E)

3.1.21

lift shaft

space through which the lift and the counterweight (if any) move. This space is materially enclosed by the bottom of the pit, the approximately vertical walls and the ceiling

3.1.22

means of escape

structural means whereby a safe route is provided for persons to travel from any point in a building to a place of safety

3.1.23

mixed-use development

structural combination of a number of premises that can include areas providing common access/egress within a building, for example a premises containing a multiplex cinema, shops, residential areas and offices

3.1.24

over-pressure relief

provision for releasing excess pressurizing air from the pressurized space

3.1.25

over-pressure relief vent

device which opens automatically at a certain pressure difference (design pressure difference) to give a free flow path from a pressurized space (e.g. staircase or lift shaft) to a space of lower pressure (e.g. lobby, accommodation) or to the open air

3.1.26

pressure differential system

system of fans, ducts, vents, and other features provided for the purpose of creating a lower pressure in the fire zone than in the protected space

3.1.27

pressurization

smoke control using pressure differentials, where the air pressure in the spaces being protected is raised above that in the fire zone

3.1.28

pressurized space

shaft, lobby, corridor, or other compartment in which the air pressure is maintained at a higher value than that of the fire zone

3.1.29

protected escape routes

route from the accommodation to a final exit, comprising one or more of the following:

- protected stairwell,
- protected lobby and/or
- protected corridor

3.1.30

refuge

area which is both separated from a fire by a fire-resisting construction and provided with a safe route to a storey exit, thus constituting a temporarily safe place during evacuation

3.1.31

replacement air

see air inlet



3.1.32**residential accommodation**

accommodation where each dwelling is a fire-compartment in its own right, such as apartments or maisonettes

3.1.33**simple lobby**

lobby which does not give access to lifts, shafts, or ducts that could constitute an appreciable leakage path for smoke to spread to other levels within the building. A lobby connected to a lift well or other shaft is still a simple lobby if all such shafts are pressurized. A simple lobby may be either unventilated or naturally ventilated

3.1.34**smoke control**

management of the movement of smoky gases within a building to ensure adequate fire safety

3.1.35**stack effect**

pressure differential resulting from a difference in density between two interconnected columns of air at different temperatures

3.2 Symbols and units

For the purposes of this document, mathematical and physical quantities are represented by symbols, and expressed in units, as given below.

A_1, A_2, A_3, A_4, A_N	m^2	leakage areas of N parallel paths;
A_D	m^2	total effective leakage area of all doors out of the pressurized space with the prescribed doors open;
A_d	m^2	leakage area of one lift door;
A_{door}	m^2	area of the opening through which pressurizing air will pass when a door is open;
A_e	m^2	total effective leakage area of a path through which air from a pressurized space passes;
A_F	m^2	total leakage area between a lift well and the external air;
A_{Floor}	m^2	area of the floor as defined in Table A.6;
A_G	m^2	door leakage area including area of any airflow grilles or large gaps for air transfer. Used to calculate the value of K ;
A_{LF}	m^2	total leakage area through the floor as defined in Table A.6;
A_{LW}	m^2	total leakage area through the walls as defined in Table A.5;
A_{PV}	m^2	area of the pressure operated relief vent;
A_{rem}	m^2	leakage area from the lobby other than through the open door;
A_t	m^2	total leakage area between all lift doors and the lift well;
A_{VA}	m^2	air release vent area per storey;
A_{VS}	m^2	net vent area per storey maintained throughout the route to the outside of the building i.e. from the accommodation into a shaft, the shaft cross sectional area and the top vent area (shaft to atmosphere);
A_W	m^2	total effective leakage area of all windows out of the space;
A_{Wall}	m^2	area of the walls as defined in Table A.5;

EN 12101-6:2005 (E)

A_X	m^2	minimum cross-sectional area of extract branch ductwork (this may be a ductwork cross section or the balancing device at the orifice or damper);
D_A	m^2	door area;
D	m	distance from the door handle centre to the nearest vertical edge of the door;
F_{dc}	N	force needed to be applied at the door handle to overcome the inherent resistance of the door to opening without a pressure differential applied to the door;
K	–	factor derived from Table A.1;
N_L	–	number of pressurized lobbies opening into the lift well;
P_R	Pa	pressurization level in the pressurized space;
P_L	Pa	pressure differential between the lift lobby or other space and external air;
P_{US}	Pa	pressure in the unpressurized space needed to relieve the pressurizing air through the air release vents;
P_{LOB}	Pa	pressure in the lobby when the door is open into the unpressurized space;
Q	m^3/s	airflow into or out of a pressurized space;
Q_D	m^3/s	air leakage rate via gaps around closed doors;
Q_{DC}	m^3/s	total identified leakage rate from the pressurized space with the doors closed;
Q_{DO}	m^3/s	air leakage rate through open doors or large openings;
Q_{fr}	m^3/s	air supply needed to provide the required airflow through the open door into the fire room;
Q_{Ld}	m^3/s	air leakage rate via lift landing doors;
Q_{Lob}	m^3/s	the air supply needed to provide the required air flow through the open door into the fire room;
Q_n	m^3/s	door leakage rate at the design pressurization as calculated for a ventilated toilet or other areas that are directly connected to the pressurized space;
Q_{Other}	m^3/s	air leakage rate via other paths that may exist;
Q_p	m^3/s	air supply to the stair or lobby needed to satisfy the pressure differential requirement;
Q_s	m^3/s	total air supply rate required with all doors closed;
Q_{SDO}	m^3/s	total air supply rate including leakage from supply ducting;
Q_{Tm}	m^3/s	air leakage rate via mechanical extraction from a toilet or other areas;
Q_{Tn}	m^3/s	leakage by natural means into the toilet (or other) space;
Q_{Window}	m^3/s	air leakage rate via cracks around windows;
R	–	index that can vary between 1 and 2, depending on the type of leakage path being considered;
W_d	m	door width.

4 System classification for buildings

4.1 General

Smoke control using pressure differentials is implemented in several different classifications of systems, with differing requirements and design conditions.

The design conditions have been placed in separate system classes which may be used to implement a design using pressure differentials for any given type of building.

The classes of system are given in Table 1.

Table 1 — Classes of systems

System class	Examples of use	Design conditions
Class A System	For means of escape. Defend in place	4.2 and Figure 2
Class B System	For means of escape and firefighting	4.3 and Figure 3
Class C System	For means of escape by simultaneous evacuation	4.4 and Figure 4
Class D System	For means of escape. Sleeping risk	4.5 and Figure 5
Class E System	For means of escape by phased evacuation	4.6 and Figure 6
Class F System	Firefighting system and means of escape	4.7 and Figure 7

The system examples to be applied will depend on national provisions valid in the place of use of the system or the decision of appropriate authorities.

4.2 Class A pressurization system

4.2.1 General

The design conditions are based on the assumption that a building will not be evacuated unless directly threatened by fire. The level of fire compartmentation is such that it is usually safe for occupants to remain within the building. Therefore, it is unlikely that more than one door onto the protected space (either that between the stair and the lobby/corridor, or the final exit door) will be open simultaneously.

Class A system shall not be used in mixed use developments.

4.2.2 Class A requirements

4.2.2.1 Airflow criterion

The airflow through the doorway between the pressurized stair and the lobby or corridor shall be not less than 0,75 m/s when:

- on any one storey the doors between the lobby/corridor and the pressurized stair are open;
- the air release from the lobby/corridor on that storey is open;
- on all other storeys all doors between the pressurized stair and the lobbies/corridors are closed;

EN 12101-6:2005 (E)

- d) all doors between the pressurized stair and the final exit are closed;
- e) the final exit door is closed.

The design requirements for a Class A system are shown in Figure 2.

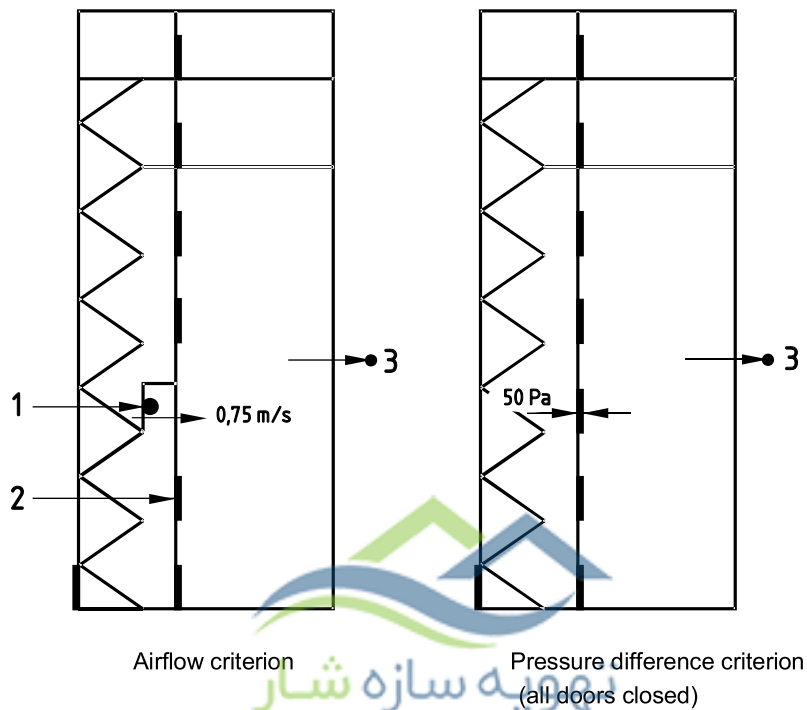

Key

- 1 Door open
- 2 Door closed
- 3 Air release path

NOTE The open door can indicate an open flow path through a simple lobby.

Figure 2 — Design conditions for Class A systems

4.2.2.2 Pressure difference criterion

The pressure difference across a closed door between the pressurized stair and the lobby/corridor shall be not less than $50 \text{ Pa} \pm 10 \%$ when:

- a) the air release from the lobby/corridor on that storey is open;
- b) on all other storeys the doors between the pressurized stair and the lobby/corridor are closed;
- c) all doors between the pressurized stair and the final exit are closed;
- d) the final exit door is closed.

NOTE The $\pm 10 \%$ is not for use in the calculation but for flexibility in the acceptance test results.

4.2.2.3 Door opening force

The system shall be designed so that the force on the door handle shall not exceed 100 N.

NOTE 1 The corresponding maximum pressure differential across the door can be determined using the procedure in Clause 15 and Annex A, as a function of the door configuration.

NOTE 2 The force that can be exerted to open a door will be limited by the friction between the shoes and the floor and it may be necessary to avoid having slippery floor surfaces near doors opening into pressurized spaces, particularly in buildings in which there are very young, elderly or infirm persons.

4.3 Class B pressurization system

4.3.1 General

A Class B pressure differential system can be used to minimise the potential for serious contamination of firefighting shafts by smoke during means of escape and fire service operations.

During firefighting operations it will be necessary to open the door between the firefighting lobby and the accommodation to deal with a potentially fully developed fire.

In some fire situations it may be necessary to connect hoses to fire mains at a storey below the fire storey and trail these via the stair to the lobby on the fire storey. It is, therefore, often not possible to close the doors between these lobbies and the stair whilst firefighting operations are in progress. The velocity of hot smoke and gases from a fully developed fire could reach 5 m/s and under these conditions it would be impractical to provide sufficient through-flow of air wholly to prevent ingress of smoke into the lobby. It is assumed that firefighting operations, such as the use of spray, contribute significantly to the holding back of hot smoky gases. It is, however, essential that the stair shaft be kept clear of serious smoke contamination. To limit the spread of smoke from the fire zone to the lobby and then through the open door between the lobby and the staircase, a velocity of at least 2 m/s shall be achieved at the lobby/accommodation door.

To achieve the minimum velocity of 2 m/s through the open stair door it is necessary to ensure sufficient leakage from the accommodation to the exterior of the building. In the later stages of fire development more than adequate leakage will generally be provided by breakage of external glazing. However, it cannot be assumed that windows will have failed before fire service arrival, and it is therefore necessary to ensure that sufficient leakage area is available via the external facade, the ventilation ductwork or specifically designed air release paths.

4.3.2 Class B requirements

4.3.2.1 Pressure difference criterion

The air supply shall be sufficient to maintain the pressure differential given in Table 2 when all doors to the lift, stair and lobby, and the final exit doors are closed and the air release path from the accommodation area is open.

The system shall be designed so that the stairwell and lobby and, where provided, the lift shaft are kept clear of smoke. In the event of smoke entering the lobby, the pressure within the stair shall not drive smoke into the lift shaft or vice-versa. This shall be achieved by providing separate pressurization of the firefighting lift shaft, lobby and stair.

The fan/motor units supplying air to the firefighting lift shaft shall be within its associated stairwell, but with separate supply ductwork.

The design requirements for a Class B system are shown in Figure 3.

Table 2 — Allowable minimum pressure differentials between specified areas for Class B systems

Specified area	Pressure differential to be maintained, min.
Across lift well and accommodation area	50 Pa
Across stairway and accommodation area	50 Pa
Across closed doors between each lobby and accommodation area	45 Pa
NOTE For flexibility in the acceptance test results there is $\pm 10\%$ tolerance on the measurement allowed.	

4.3.2.2 Airflow criterion

The air supply shall be sufficient to maintain a minimum airflow of 2 m/s through the open door between the lobby and the accommodation at the fire affected storey with all of the following doors open between:

- a) the stair and the lobby on the fire affected storey;
- b) the stair and the lobby on an adjacent storey;
- c) the firefighting lift shaft and the lobby on the adjacent storey;
- d) the stair and the external air at the fire service access level;

and the air release path on the fire floor is open.

If a door that has two leaves is assumed to be open for calculation purposes, one leaf may be assumed to be in the closed position for these calculations.

The number of open doors assumed for design shall depend upon the location and type of firefighting facilities installed in the building, and in particular rising main outlets.

Where the hose passes through a door, that door shall be considered to be fully open.

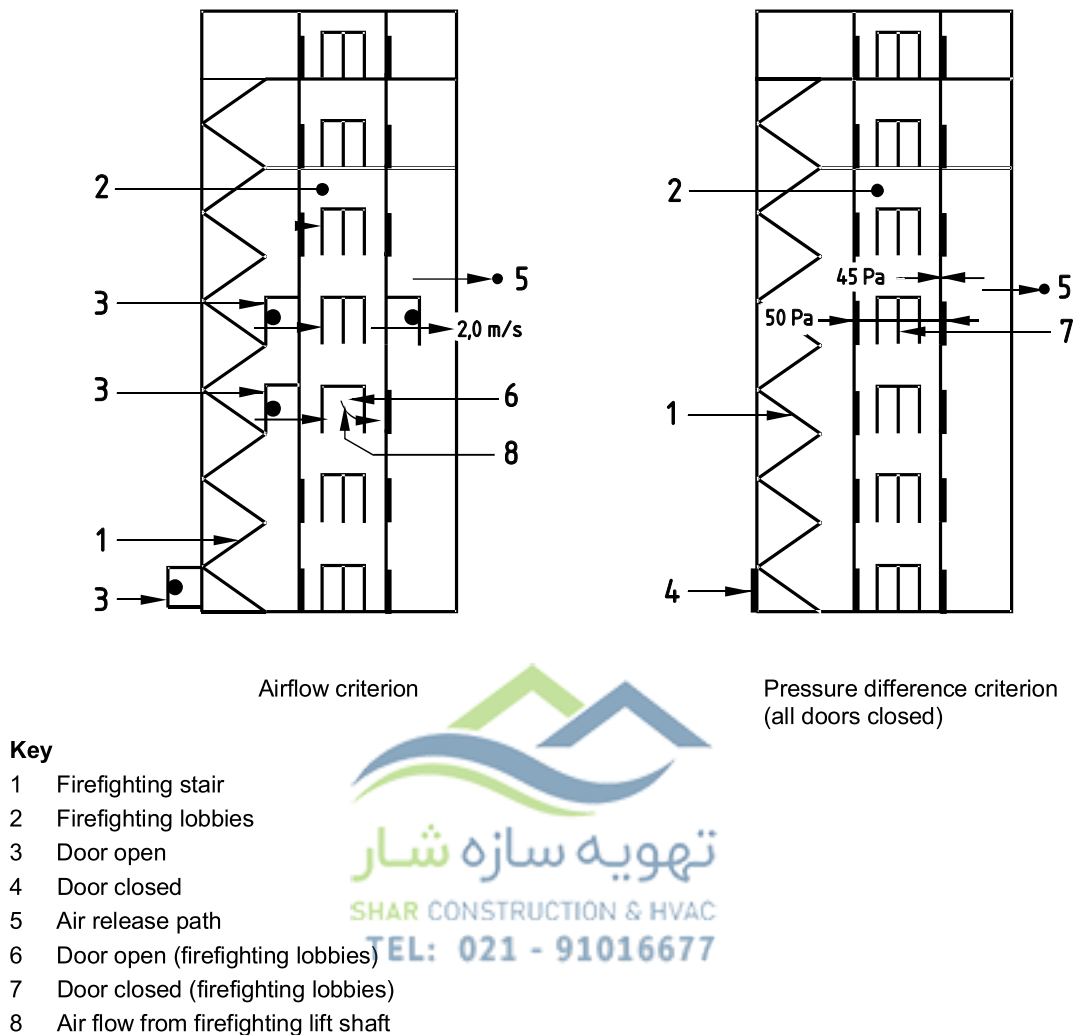

Figure 3 — Design conditions for Class B systems

4.3.2.3 Air supply

Any air supply serving a firefighting staircase or lift shaft, and their associated lobbies where present, shall be separate from any other ventilation or pressure differential system.

4.3.2.4 Firefighting shaft

Firefighting shafts shall be constructed in accordance with the appropriate national provisions valid in the place of use of the system.

4.3.2.5 Door opening force

The system shall be designed so that the force on the door handle shall not exceed 100 N.

NOTE 1 The corresponding maximum pressure differential across the door can be determined using the procedure in Clause 15 and Annex A, as a function of the door configuration.

EN 12101-6:2005 (E)

NOTE 2 The force that can be exerted to open a door will be limited by the friction between the shoes and the floor and it may be necessary to avoid having slippery floor surfaces near doors opening into pressurized spaces, particularly in buildings in which there are very young, elderly or infirm persons.

4.4 Class C pressurization system

4.4.1 General

The design conditions for Class C systems are based on the assumption that the occupants of the building will all be evacuated on the activation of the fire alarm signal that is simultaneous evacuation.

In the event of a simultaneous evacuation it is assumed that the stairways will be occupied for the nominal period of the evacuation, and thereafter will be clear of evacuees. Consequently, the evacuation will occur during the early stages of fire development, and some smoke leakage onto the stairway can be tolerated. The airflow due to the pressurization system shall clear the stairway of this smoke.

The occupants being evacuated are assumed to be alert and aware, and familiar with their surroundings, thus minimising the time they remain in the building.

4.4.2 Class C requirements

4.4.2.1 Airflow criterion

The airflow velocity through the doorway between the pressurized space and the accommodation shall be not less than 0,75 m/s when:

- a) on the fire floor the doors between the accommodation and the pressurized staircase and lobby are open;
- b) the air release path from the accommodation, on the fire floor where the air velocity is being measured, is open;
- c) all other doors other than the fire floor doors are assumed to be closed.

4.4.2.2 Pressure difference

The pressure difference across a closed door between the pressurized space and the accommodation area shall be as given in Table 3.

Table 3 — Minimum pressure differentials for Class C systems

Position of doors	Pressure differentials to be maintained, min.
i) Doors between accommodation area and the pressurized space are closed on all storeys	50 Pa
ii) All doors between the pressurized stair and the final exit are closed	
iii) Air release path from the accommodation on the storey where the pressure difference being measured is open	
iv) Final exit door is closed	
v) Final exit door is open and items i) to iii) above are complied with	10 Pa
NOTE For flexibility in the acceptance test results there is $\pm 10\%$ tolerance on the measurement allowed.	

The design conditions for Class C systems are shown in Figure 4.

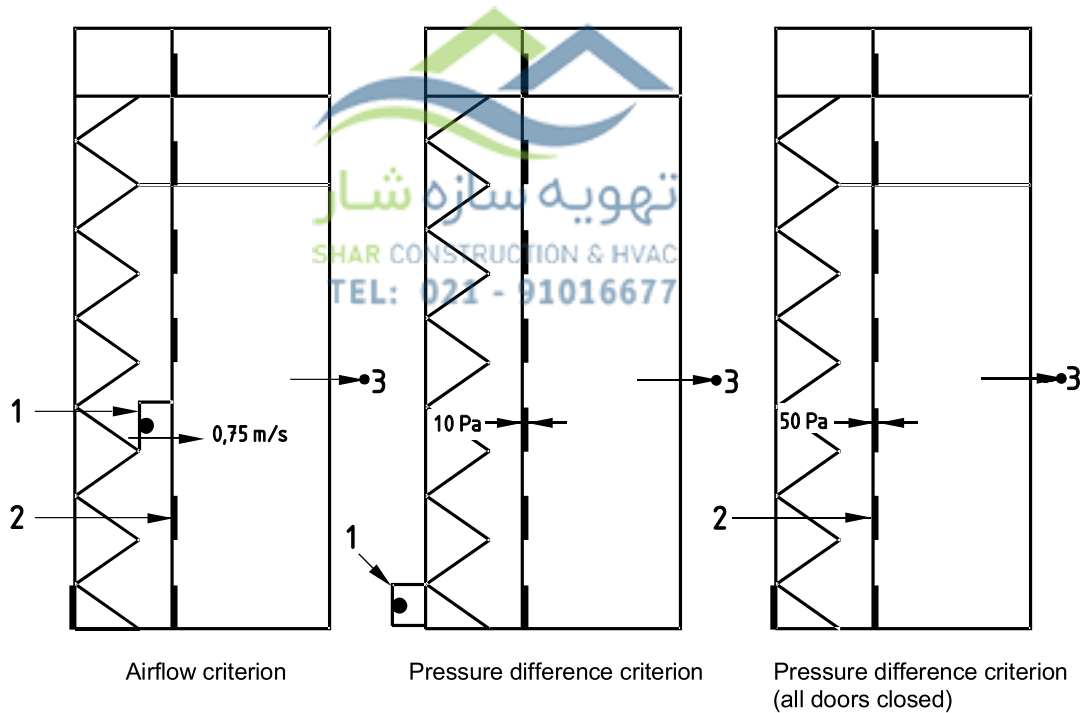

Key

- 1 Door open
- 2 Door closed
- 3 Air release path

NOTE Figure 4 can include lobbies.

Figure 4 — Design conditions for Class C systems

4.4.2.3 Door opening force

The system shall be designed so that the force on the door handle shall not exceed 100 N.

NOTE 1 The corresponding maximum pressure differential across the door can be determined using the procedure in Clause 15 and Annex A, as a function of the door configuration.

NOTE 2 The force that can be exerted to open a door will be limited by the friction between the shoes and the floor and it may be necessary to avoid having slippery floor surfaces near doors opening into pressurized spaces, particularly in buildings in which there are very young, elderly or infirm persons.

4.5 Class D pressurization system

4.5.1 General

Class D systems are designed in buildings where the occupants may be sleeping, e.g. hotels, hostels and institutional-type buildings. The time for the occupants to move into a protected area prior to reaching the final exit can be greater than that expected in an alert or able-bodied environment, and occupants may be unfamiliar with the building or need assistance to reach the final exit/protected space.

Class D systems are also appropriate when the presence of a pressure differential system has served to justify the absence of a discounted stairway and/or lobbies that would normally be required under the national provisions valid in the place of use of the system.

4.5.2 Class D requirements

4.5.2.1 Airflow criterion

The airflow through the doorway between the pressurized space and the accommodation on the fire floor shall be not less than 0,75 m/s when:

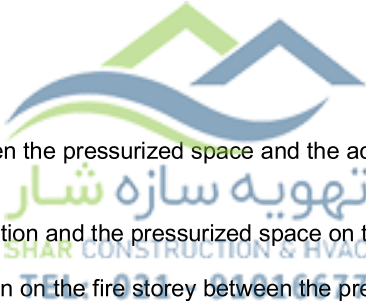
- 
- a) the door between the accommodation and the pressurized space on the fire storey is open and/or
 - b) all doors within the accommodation on the fire storey between the pressurized space and the air release path are open and/or
 - c) all doors within the pressurized spaces on that fire floor to the final exit which cross the escape route from the accommodation exit are open and/or
 - d) all doors between the pressurized stair and the final exit are open and/or
 - e) the final exit door is open and/or
 - f) the air release from the accommodation on the fire floor is open.

4.5.2.2 Pressure difference

The pressure difference across the door between the pressurized space and the accommodation area on the fire storey shall be as given in Table 4.

Table 4 — Minimum pressure differentials for Class D systems

Position of doors	Pressure differential to be maintained, min.
Door between accommodation area and the pressurized space on the fire storey is closed.	10 Pa
All doors within the pressurized space that cross the escape route from the accommodation area to the final exit door are open	
All doors between the pressurized stair and the final exit door are open	
The final exit door is open	
The air release path from the accommodation area on the storey where the pressure difference is being measured is open	
A door to a floor other than the fire floor is open	
The doors between the accommodation area and the pressurized space are closed on all storeys	50 Pa
All doors between the pressurized stair and the final exit door are closed	
The air release path from the accommodation area on the storey where the pressure difference is being measured is open	
The final exit door is closed	
NOTE For flexibility in the acceptance test results there is $\pm 10\%$ tolerance on the measurement allowed.	

The design conditions for Class D systems are shown in Figure 5.

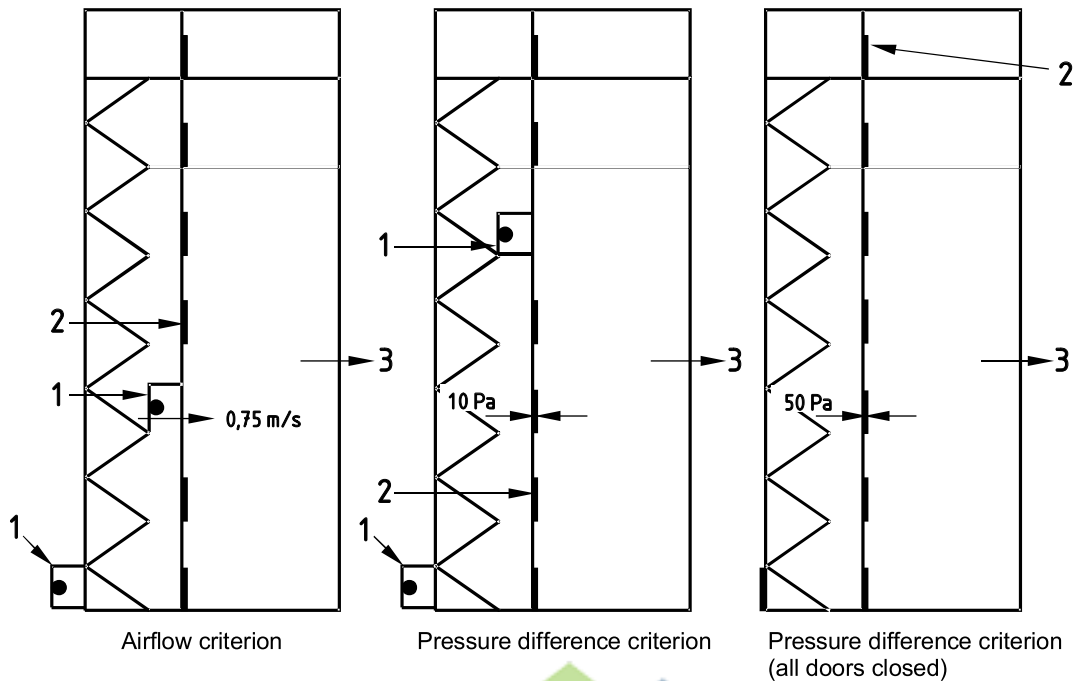

Key

- 1 Door open
- 2 Door closed
- 3 Air release path

NOTE Figure 5 can include lobbies.

Figure 5 — Design conditions for Class D systems



4.5.2.3 Door opening forces

The system shall be designed so that the force on the door handle shall not exceed 100 N.

NOTE 1 The corresponding maximum pressure differential across the door can be determined using the procedure in Clause 15 and Annex A, as a function of the door configuration.

NOTE 2 The force that can be exerted to open a door will be limited by the friction between the shoes and the floor and it may be necessary to avoid having slippery floor surfaces near doors opening into pressurized spaces, particularly in buildings in which there are very young, elderly or infirm persons.

4.6 Class E pressurization system

4.6.1 General

A Class E system is a system used in buildings where the means of escape in case of fire is by phased evacuation.

In the “phased evacuation” scenario it is considered that the building will still be occupied for a considerable time whilst the fire is developing, creating greater fire pressures in addition to greater amounts of hot smoke and gas (this can vary greatly according to the type of materials, fire load involved and the geometry of the fire load).

In the “phased evacuation” situation, the protected staircases shall be maintained free of smoke to allow persons to escape in safety from floors, other than the fire floor, at a later stage in the fire development.

4.6.2 Class E requirements

4.6.2.1 Airflow criterion

The airflow through the open doorway between the pressurized space and the accommodation area on the fire floor shall be not less than 0,75 m/s when:

- a) the doors between the accommodation area and the pressurized space on the storey above the fire floor are open and/or
- b) all doors within the pressurized spaces on those two storeys that cross the escape route from the accommodation area to the final exit are open and/or
- c) all doors between the pressurized stair and the final exit are open and/or
- d) the final exit door is open and/or
- e) the air release path from the accommodation area on the fire floor is open.

4.6.2.2 Pressure difference criterion

The pressure difference across the closed door between the pressurized space and the accommodation area on the fire floor shall be not less than as shown in Table 5.



Table 5 — Minimum pressure differentials for Class E systems

Position of doors	Pressure differential to be maintained, min.
The doors between the accommodation area and the pressurized space are open on two adjacent storeys	10 Pa
All doors within the pressurized space on those two storeys that cross the escape route from the accommodation area to the final exit door are open	
All doors between the pressurized stair and the final exit door are open	
The final exit door is open	
The air release path from the accommodation area on the storey where the pressure difference being measured is open	
The doors between the accommodation area and the pressurized space on all storeys are closed	50 Pa
All doors between the pressurized stair and the final exit door are closed	
The air release path from the accommodation area on the storey where the pressure difference being measured is open	
The final exit door is closed	
NOTE For flexibility in the acceptance test results there is $\pm 10\%$ tolerance on the measurement allowed.	

The design conditions for Class E systems are shown in Figure 6.

4.6.2.3 Door opening force

The system shall be designed so that the force on the door handle shall not exceed 100 N.

NOTE 1 The corresponding maximum pressure differential across the door can be determined using the procedure in Clause 15 and Annex A, as a function of the door configuration.

NOTE 2 The force that can be exerted to open a door will be limited by the friction between the shoes and the floor and it may be necessary to avoid having slippery floor surfaces near doors opening into pressurized spaces, particularly in buildings in which there are very young, elderly or infirm persons.

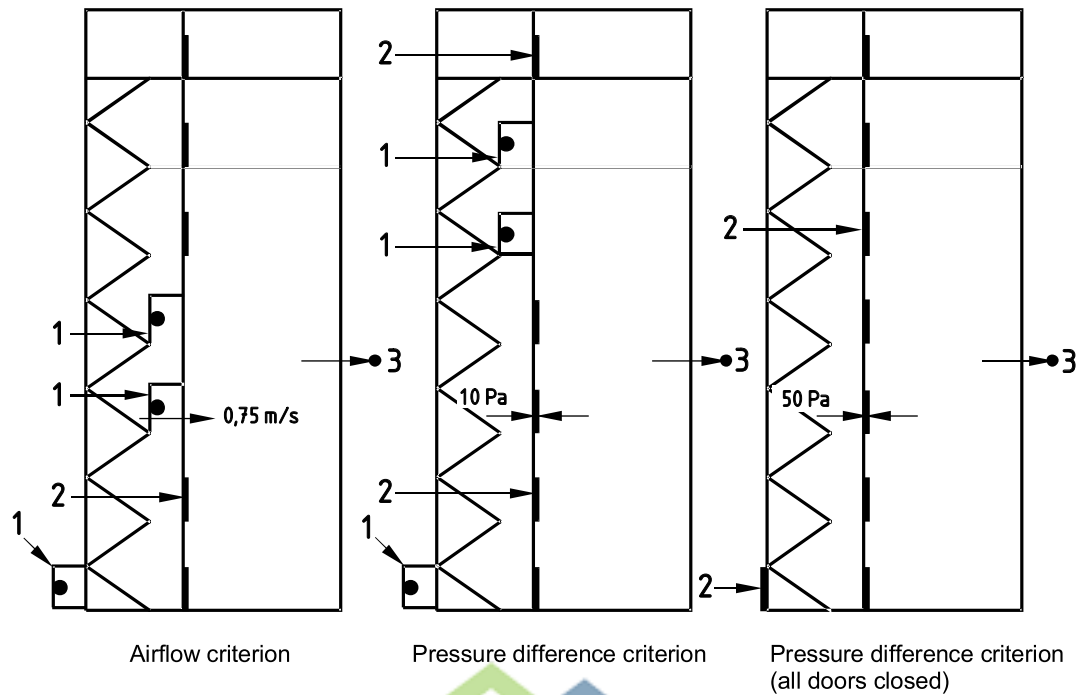
**Key**

- 1 Door open
- 2 Door closed
- 3 Air release path

NOTE Figure 6 can include lobbies.

Figure 6 — Design conditions for Class E systems

4.7 Class F pressurization systems

4.7.1 General

A Class F pressure differential system can be used to minimise the potential for serious contamination of firefighting staircases by smoke during means of escape and fire service operations.

During firefighting operations it will be necessary to open the door between the firefighting lobby and the accommodation to deal with a potentially fully developed fire.

In some fire situations it may be necessary to connect hoses to fire mains at a storey below the fire storey and trail these via the stair to the lobby on the fire storey. It is, therefore, often not possible to close the doors between these lobbies and the stair whilst firefighting operations are in progress. If the rising main outlets are only inside the corridor or the accommodation in front of the lobbies, the door between lobby and corridor or accommodation on the storey below the fire storey has additionally to be assumed to be open during firefighting operations.

The velocity of hot smoke and gases from a fully developed fire could reach 5 m/s and under these conditions it would be impractical to provide sufficient through-flow of air wholly to prevent ingress of smoke into the lobby. It is assumed that firefighting operations, such as the use of spray, contribute significantly to the holding back of hot smoky gases. It is, however, essential that the staircase be kept clear of serious smoke contamination. To limit the spread of smoke from the fire zone to the lobby, and then through the open door between the lobby and the staircase, a velocity of at least 2 m/s shall be achieved at the door between staircase and lobby when all doors from the lobby to the accommodation are open.

EN 12101-6:2005 (E)

Since the velocity in the doors between the lobby and the accommodation may be lower than 2 m/s and therefore smoke may enter the lobby from the accommodation, this smoke shall be removed from the lobby by achieving a sufficient air exchange rate in the lobby when all lobby doors are closed.

To achieve the minimum velocity of 2 m/s through the open stair door it is necessary to ensure sufficient leakage from the accommodation to the exterior of the building. In the later stages of fire development more than adequate leakage will generally be provided by breakage of external glazing. However, it cannot be assumed that windows will have failed before fire service arrival, and it is therefore necessary to ensure that sufficient leakage area is available via the external facade, the ventilation ductwork or specifically designed air release paths.

4.7.2 Class F requirements

4.7.2.1 Pressure difference criterion

The air supply shall be sufficient to maintain the pressure differential given in Table 6 when all doors to the lift, stair and lobby, and the final exit doors, are closed and the air release path from the accommodation area is open.

The system shall be designed so that the stairwell and, where provided, the lift shaft are kept clear of smoke. In the event of smoke entering the lobby, the pressure within the stair shall not drive smoke into the lift shaft or vice-versa. This shall be achieved by providing separate pressurization of the firefighting lift shaft on one hand and the lobby and stair on the other hand. One fan/motor unit supplying air to the firefighting lift shaft and its associated stairwell may be used, but with separate supply ductwork.

Table 6 — Minimum pressure differentials between specified areas for Class F systems when all doors are closed

Specified area	Pressure differential to be maintained, min.
Across lift well and accommodation area	50 Pa
Across stairway and accommodation area	50 Pa
Across closed doors between each lobby and accommodation area	45 Pa
NOTE For flexibility in the acceptance test results there is $\pm 10\%$ tolerance on the measurement allowed	

4.7.2.2 Airflow criterion between staircase and lobby

The air supply shall be sufficient to maintain an airflow of 2 m/s through the open door between the staircase and the lobby at the fire affected storey with the air release path on the fire floor is open and all of the following doors are open between:

- all doors between lobby and the affected fire compartment;
- the stair and the lobby on the storey below the fire storey;
- the firefighting lift shaft and the lobby on the storey below the fire storey;
- the stair and the external air at the fire service access level;
- the lobby and the accommodation on the storey below the fire storey (this only applies where the rising main outlets are located inside the accommodation in front of the lobbies).

NOTE If a door that has two leaves is assumed to be open for calculation purposes and acceptance testing, the smaller leaf may be assumed to be in the closed position.

Where the hose passes through a door, that door shall be considered to be fully open.

4.7.2.3 Airflow criterion between the lobby and fire compartment

The air supply shall be sufficient to maintain a minimum airflow of 1 m/s through all open doors between the lobby and the affected fire compartment with (see Figure 7):

- a) the door between the staircase and the lobby closed;
- b) all doors between the lobby and adjacent accommodations on the fire storey open;
- c) the stair and the external air at the fire service access level open;
- d) the air release path of the fire affected compartment open.

Requirement c) above does not apply if there is a simple lobby between the staircase and the final exit door. All doors of this lobby shall be self closing. Alternatively, the provisions of 4.7.2.4 shall apply.



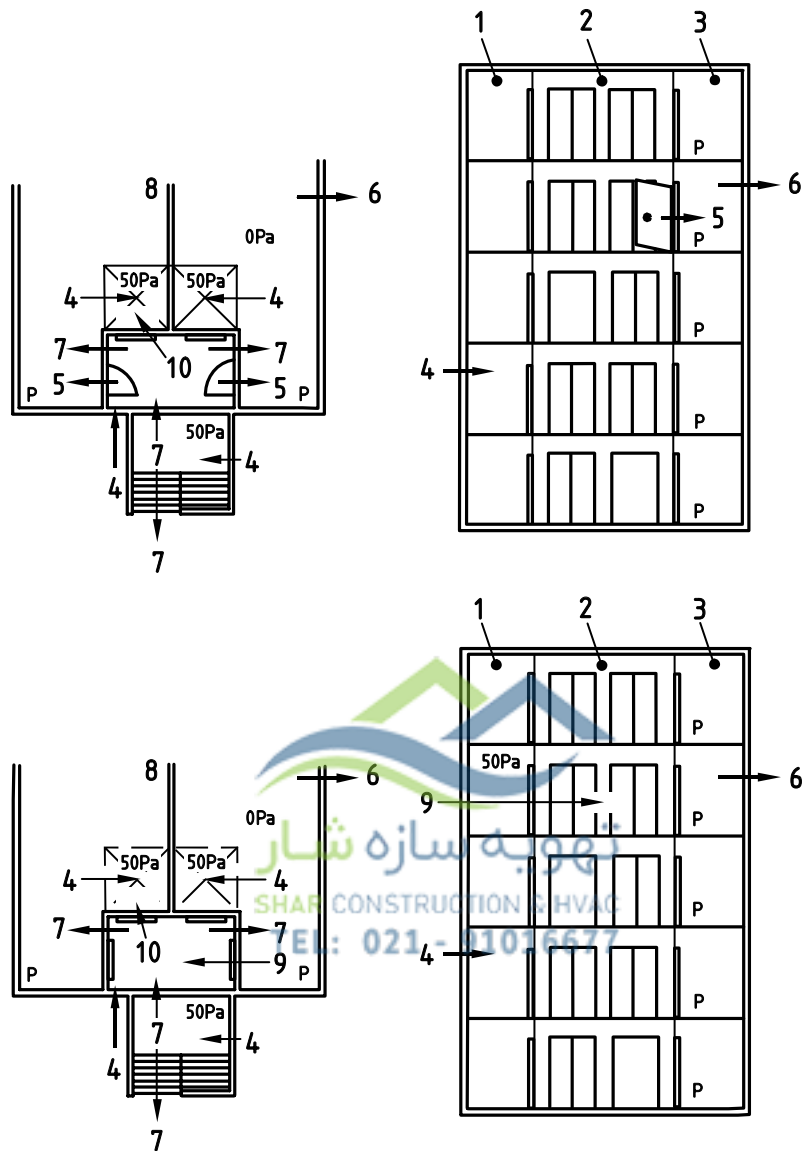

Key

- 1 Stair
- 2 Lobby
- 3 Accommodation
- 4 Supply air
- 5 Leakage path through doors, etc.
- 6 Air release path from building
- 7 Over pressure relief vent
- 8 Accommodation
- 9 Lift lobby
- 10 Lift car

Figure 7 — Design conditions for Class F systems

4.7.2.4 Alternative airflow criterion to 4.7.2.3

Maintain an air exchange rate of 30 h^{-1} in the lobby on the fire storey with (see Figure 7):

- a) all doors of the lobby including the door between the lobby and the staircase closed;
- b) the door between the stair and the external air at the fire service access level open;
- c) the air release path of the fire affected compartment open.

Requirement b) above does not apply if there is a simple lobby between the staircase and the final exit door. All doors of this lobby shall be self closing.

4.7.2.5 Air supply

Any air supply serving a firefighting staircase or lift shaft and their associated lobbies, where present, shall be separated from any other ventilation or pressure differential system.

4.7.2.6 Door opening force

The system shall be designed so that the force on the door handle shall not exceed 100 N.

NOTE 1 The corresponding maximum pressure differential across the door can be determined using the procedure in Clause 15 and Annex A, as a function of the door configuration.

NOTE 2 The force that can be exerted to open a door will be limited by the friction between the shoes and the floor and it may be necessary to avoid having slippery floor surfaces near doors opening into pressurized spaces, particularly in buildings in which there are very young, elderly or infirm persons.

5 Features of a pressurization system**5.1 General****5.1.1 Building design and construction**

The information provided in this clause covers all classes of systems and is specifically intended to cover the protection of stairwells, lobbies and corridors that form part of a protected escape route or firefighting shaft.

The aim is to establish a pressure differential across any leakage paths that will ensure that smoke moves away from the protected space. This is achieved by maintaining the protected space at a pressure higher than that of the fire zone. It is essential that adequate air release shall be provided from the accommodation to ensure that a pressure differential is maintained. See Figures 8 a) and 8 b).

In calculating the air supply needed for a pressurization system, assumptions have to be made about the leakage characteristics of the building, in particular between:

- a) pressurized and unpressurized spaces;
- b) adjoining pressurized spaces;
- c) pressurized spaces and the external air;
- d) unpressurized spaces and the external air.

EN 12101-6:2005 (E)

If pressurized and unpressurized shafts are present in the same building, the potential exists for the unpressurized shafts to become smoke logged as a direct result of the air flow created by the pressurization system.

If buildings contain spaces such as computer suites or medical facilities that are pressurized for reasons other than fire, consideration shall be given to protecting the pressurized escape routes from the effects of fire in these pressurized spaces. See Clause 8 for more detailed information.

It is essential that agreement shall be reached between the specifiers and the designers as to the installation and construction techniques that will be used in the building. Particular attention shall be paid to the construction of the shafts that will be pressurized and the building envelope. Unrealistic assumptions about the air tightness of these constructions are a common cause for pressurization systems failing to meet acceptance criteria.

It is essential that the architect/builder shall be made aware of the importance of controlling leakage areas from the pressurized spaces so that when fitted out there is not an excessive loss of pressurizing air.

In a single-stage pressurization system the pressurization is applied only when a fire occurs, and in a two-stage pressurization system a low level of air supply is maintained at all times, for example for ventilation, and is increased to the emergency level when a fire occurs. Either system is acceptable.

5.1.2 Features of a pressurization system requirements

5.1.2.1 Air intake shall be provided for drawing air in from outside the building in such a way that it is not contaminated by smoke from a fire within the building (see 11.8.2.4).

5.1.2.2 Air shall be supplied via fans and where necessary ductwork to the pressurized space. Consideration shall be given to the siting and construction of the ductwork and fans to ensure that they are not compromised by a fire from within the unprotected space.



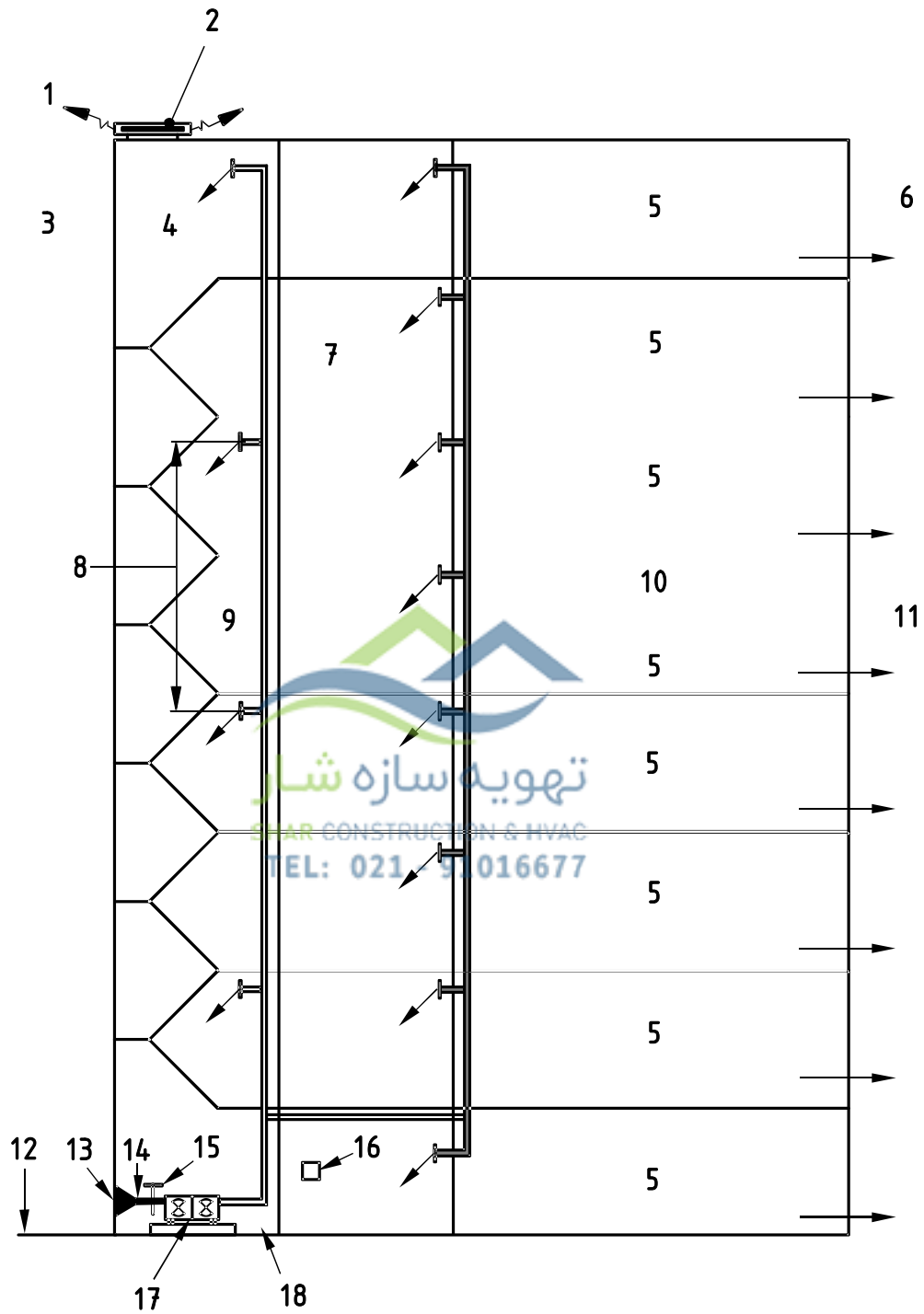

EN 12101-6:2005 (E)

Key

- 1 An alternative option is to control the fan to ensure overpressure does not exceed 60 Pa max.
- 2 Pressure relief dampers set to operate at 60Pa (max) within the stairwell enclosure
- 3 Pressurizing are discharged evenly throughout the stair height for building greater than 11 m (a single discharge normally at the top of the stair is acceptable for buildings less than 11 m)
- 4 Fire fighting stairs
- 5 Accommodation
- 6 External leakage
- 7 Pressurizing air discharged at every lobby level
- 8 Distance between air discharge to be no greater than three floor levels
- 9 Firefighting lobby access
- 10 Fire zone
- 11 Air release vents
- 12 Fire service access level
- 13 Single air intake
- 14 Smoke detector
- 15 Motorized smoke damper
- 16 Fire officers override switch
- 17 Primary and back-up pressurizing air units
- 18 Plant room that is protected by two-hour fire rated compartments and housing smoke pressurization fans

Figure 8 a) — Features of a typical bottom fed stair pressure differential system



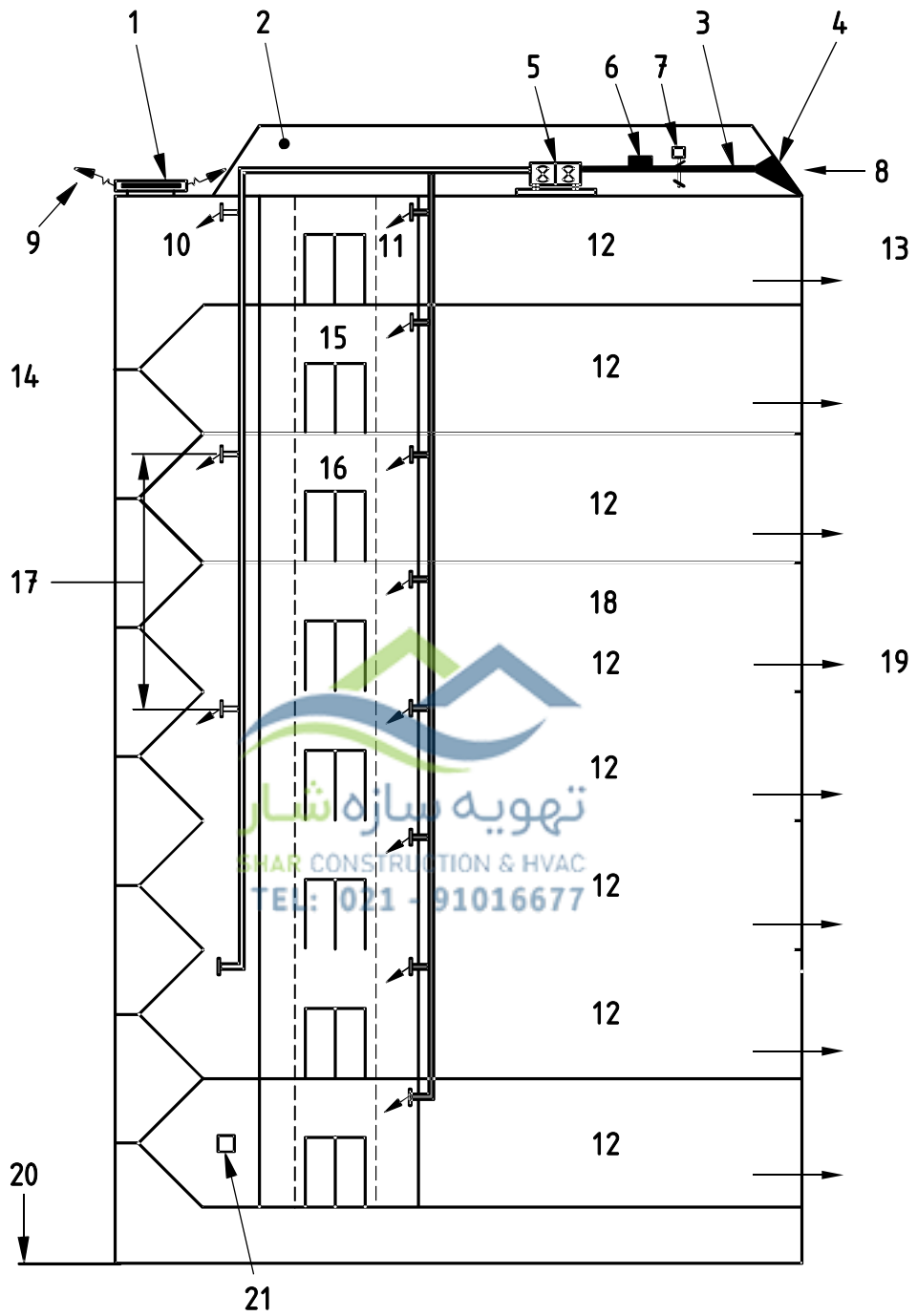

EN 12101-6:2005 (E)

Key

- 1 Pressure relief dampers set to operate at 60 Pa (max) within the stairwell
- 2 Plant room that is protected by two-hour fire rated compartments and housing smoke pressurization fans
- 3 Smoke detector
- 4 Twin air intakes to alternative facades of the building complete with smoke detector and motorised smoke damper
- 5 Primary and back-up pressurizing air units
- 6 Alternative air intake
- 7 Motorised smoke damper
- 8 Air intake
- 9 An alternative option is to control the fan to ensure over-pressure does not exceed 60 Pa max.
- 10 Firefighting stairs
- 11 Firefighting lift well (if required)
- 12 Accommodation
- 13 External leakage
- 14 Pressurizing air discharged evenly throughout the stair height for building greater than 11 m (a single discharge normally at the top of the stair is acceptable for buildings less than 11 m)
- 15 Firefighting lobby
- 16 Pressurizing air discharged at every lobby level
- 17 Distance between air discharge to be no greater than three floor levels
- 18 Fire zone
- 19 Air release vent
- 20 (Fire service) access level
- 21 Fire officers override switch



Figure 8 b) — Features of a typical top fed stair pressure differential system

5.1.2.3 All doors between pressurized and unpressurized spaces shall be fitted with automatic closing mechanisms (door closers).

5.1.2.4 Small gaps and cracks together with open doors provide leakage paths from the pressurized to unpressurized spaces. Additional over pressure relief shall be provided to ensure that the pressure build up when doors are closed does not make it difficult to open doors into the pressurized space.

5.1.2.5 Air release shall be provided for ensuring that the air flowing from the pressurized to an unpressurized space can leak to external air so as to maintain the pressure differential, or open door airflow velocity, between the two spaces.

5.1.2.6 If there are pressurized and unpressurized spaces in the same building, then it shall be demonstrated that smoke will not be forced into the unpressurized shaft. The use of pressurized and unpressurized stairwells serving the same storeys shall only be considered if either of the following conditions are met:

- a) the unpressurized stairwell is separated from the pressurized stairwell by a large undivided space from which the air can escape by an opening twice as large as the door through which the air enters, or
- b) a detailed design flow analysis has shown that operation of the pressurization system will not increase the flows of air on the fire storey into the unpressurized stairwell.

Each pressurized escape route shall have its own independent air supply.

5.2 Air supply points

5.2.1 General

In the design of stairs the aim is to ensure that there is an even distribution of pressurizing air throughout the stair and that there is no likelihood of the air supply being short circuited by open doors, i.e. air passing directly out of an open door as soon as it has been supplied to the shaft.

If doors are open near to the injection point, supply air can be lost through them and adequate pressurization may not be achieved at doors further from the injection point. This may be particularly true in the case of ground level injection systems where the exit door is likely to be open for substantial periods of time.

When a stair pressurization system is designed on the basis of an open door at final exit level, the vertical airflow in the shaft is likely to be high and consequently the pressure losses may be substantial.

5.2.2 Air supply requirements

5.2.2.1 Each vertical escape or firefighting shaft shall be provided with its own dedicated pressurization system. The ducts pressurizing each of the separate vertical shafts and/or lobbies as well as any associated pressurized corridors shall be permitted to be supplied with air from a common system. The lobby shall have pressurizing air supplied through ductwork that is independent of that supplying the stair. The corridor shall have pressurizing air supplied from a duct that is separate from the lobby and the stairwell supply.

5.2.2.2 In buildings less than 11 m in height, a single air supply point for each pressurized stairwell is acceptable.

5.2.2.3 In buildings 11 m or more in height, air supply points shall be evenly distributed throughout the height of the stairwell, and the maximum distance between air supply points shall not exceed three storeys.

5.2.2.4 The supply point shall not be located within 3 m of the final exit doors.

5.2.2.5 For lift shafts one injection/supply point shall be provided for each lift shaft up to 30 m in height.

5.2.2.6 Each lobby shall be provided with one injection/supply point.

5.3 Air release

5.3.1 General

During operation of the system, pressurizing air will flow from the pressurized space into the accommodation. It is important that provision be made on the fire storey for the air that has leaked into the unpressurized spaces to escape from the building. This is essential in order to maintain the pressure differential between pressurized spaces and the accommodation. The required leakage rate will depend on the particular layout of the building and the application of the pressurization system.

5.3.2 Air release requirements

5.3.2.1 The accommodation on the fire storey shall have specific provision for air release for the intended flow rate entering the space.

5.3.2.2 If it can be shown by an appropriate fire engineering study that sufficient leakage paths via the ventilation system will be available prior to window breakage, it is not necessary to provide additional provision for air release from the building. In the absence of such a study air release shall be provided by one of the following methods:

- a) provision of special vents at the building periphery. Where the building is sealed special vents may need to be provided on all sides of the building (see Clause 15),
- b) vertical shafts. If venting the pressurizing air by building leakage or peripheral vents is not possible, vertical shafts may be used for this purpose (see Clause 15),
- c) mechanical extraction. The release of the pressurizing air by mechanical extraction is a satisfactory method. The mechanical extraction would be required to operate only during the period prior to window breakage (see Clause 15).

5.3.2.3 In assessing the effective area of natural air release venting required per storey, one side of the building shall be disregarded for the purpose of calculation. If the venting is not evenly distributed around the external wall, the side with the largest area of venting shall be discounted for the calculation.

5.3.2.4 The required air release provision shall be calculated to take into account the particular layout of the building and the type of pressurization system.

5.3.2.5 Where the air release is provided by natural vents:

- a) the natural vent(s) shall normally be held in the closed position, and
- b) when the emergency pressurization system operates, the vent(s) shall be released so that the pressurizing air is free to escape.

When automatically controlled release venting is used, the venting shall take place on the fire storey only and the air release vents on all other storeys shall remain closed.

5.3.2.6 Where the air release is provided by powered vents, the exhaust rate per storey shall be not less than the calculated maximum flow rate (see 15.2 and A.4) into the accommodation and means shall be provided that the door opening force does not exceed 100 N with the door shut.

5.3.2.7 The requirement in 5.3.2.6 can be achieved by having a separate exhaust system for each storey, or by arranging for the ducts on all storeys to be normally closed by modified fire-resisting smoke control dampers. When the emergency pressurization system operates, the dampers closing the extract system shall open on the fire storeys only.

5.4 Overpressure relief

5.4.1 General

The design of pressurized stairwells involves evaluating the required airflow under two different conditions, i.e. all doors closed and with selected doors open. In most circumstances the airflow requirement with doors open will be greater than with all doors closed. If excessive pressures are allowed to develop in the protected space it may become difficult or impossible to open doors into the space (see Clause 15). To prevent the build up of excessive pressures it is necessary to provide overpressure relief vents. The pressure relief vent area may be closed by a counter-balanced flap valve so designed that it will only open when the pressure exceeds the design pressure.

Alternatively it is possible to utilise a system controlled by pressure sensors so that the air supply or exhaust can be continuously varied to produce the pressure or flow required.

5.4.2 Overpressure relief requirements

5.4.2.1 Means shall be provided for the release of excess pressurizing air from the protected space.

5.4.2.2 Overpressure relief vents shall not discharge into the accommodation via an unprotected flow path, because any penetration of a fire-resisting barrier represents a potential weakness between the protected space and the fire zone. The overpressure relief from the pressurized space shall discharge either:

- a) directly to external air or via appropriate ductwork, or
- b) for Class F systems, if the overpressure relief vent discharges into the accommodation, the penetration of the fire-resisting barrier shall be protected by an automatically self closing fire damper classified in accordance with prEN 13501-3 and only operated by a temperature device.

5.4.2.3 The overpressure relief vent shall be sized such that it is capable of discharging the total excess airflow, determined by subtracting the total air leakage from the stairwells, lobbies and corridors with all doors closed from the total required airflow rate under the most onerous air supply conditions.

5.4.2.4 The overpressure relief shall be capable of ensuring that the pressurization level within the protected space (with all doors closed) is maintained at or above the design pressurization level but below the maximum pressure determined by the door opening force requirements (see Clause 15).

5.4.2.5 Variable supply fans or dampers controlled by pressure sensors shall not be used unless the system can achieve over 90 % of the new air supply requirements within 3 s of a door being opened or closed.

6 Spaces to be pressurized

6.1 Stairwells only

6.1.1 General

The protection given by pressurizing stairwells only confined to the vertical part of the escape route; no significant protection is afforded to the horizontal part of the escape route on each storey.

6.1.2 Requirements for stairwells

6.1.2.1 If the stairwells only are pressurized, the stair shall be approached directly from the accommodation or through a simple lobby.

6.1.2.2 With all doors closed the pressure difference across the doors shall be as shown in Figure 9.A and Figure 9.B.

EN 12101-6:2005 (E)

6.1.2.3 Systems pressurizing the stairwells shall be activated simultaneously, whenever there is a fire alarm signal.

6.1.2.4 The arrangements shall comply with the appropriate class of system as defined in Clause 4.

6.2 Stairwells and lobby

6.2.1 General

If, on any storey, the lobby separating the stairwell from the accommodation is other than a simple lobby, this lobby shall be pressurized independently of the stairwell. This arrangement will carry the protection against smoke ingress right up to the door leading towards the accommodation area in which a fire might occur (see Figure 10 and 5.3).

NOTE A lobby connected to a lift well or other shaft is still considered to be a simple lobby if all such shafts are pressurized independently.

6.2.2 Requirements for stairwells and lobby

6.2.2.1 With all doors closed, the pressure differences with respect to the accommodation shall be as shown in Figure 10.

6.2.2.2 When smoke is detected, either:

- a) all pressurized stairwells and pressurized lobbies on all storeys shall be pressurized simultaneously, or
- b) all stairwells and only the lobbies on the fire incident floor shall be pressurized.

6.2.2.3 The arrangements shall comply with the appropriate class of system as defined in Clause 4. Where there is a simple lobby between stairwell and accommodation, any "open door" condition specified in Clause 4 will apply to both doors in the specified lobby, forming a single flow path.

NOTE Where the situation arises of a pressurized lobby with two or more doors opening into the accommodation on a single storey, this situation should be subject to a fire engineered solution, in terms of air flow, and of air release, especially where the doors open into separate flow paths leading to different air release paths.

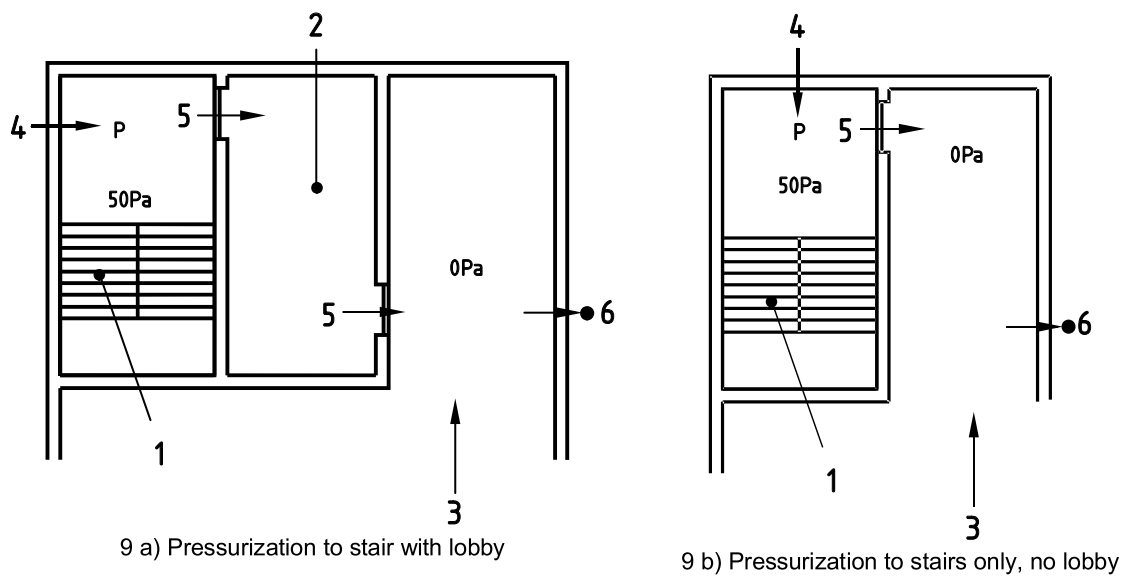

Key

- 1 Stair
- 2 Lobby
- 3 Accommodation
- 4 Supply air
- 5 Leakage path through doors, etc.
- 6 Air release path from building

P denotes pressurized space. Encircled number denotes minimum design pressure differential, e.g. 50 (Pascals) relative to accommodation, identified by 0

Figure 9 — Pressurization to stair only with or without lobby

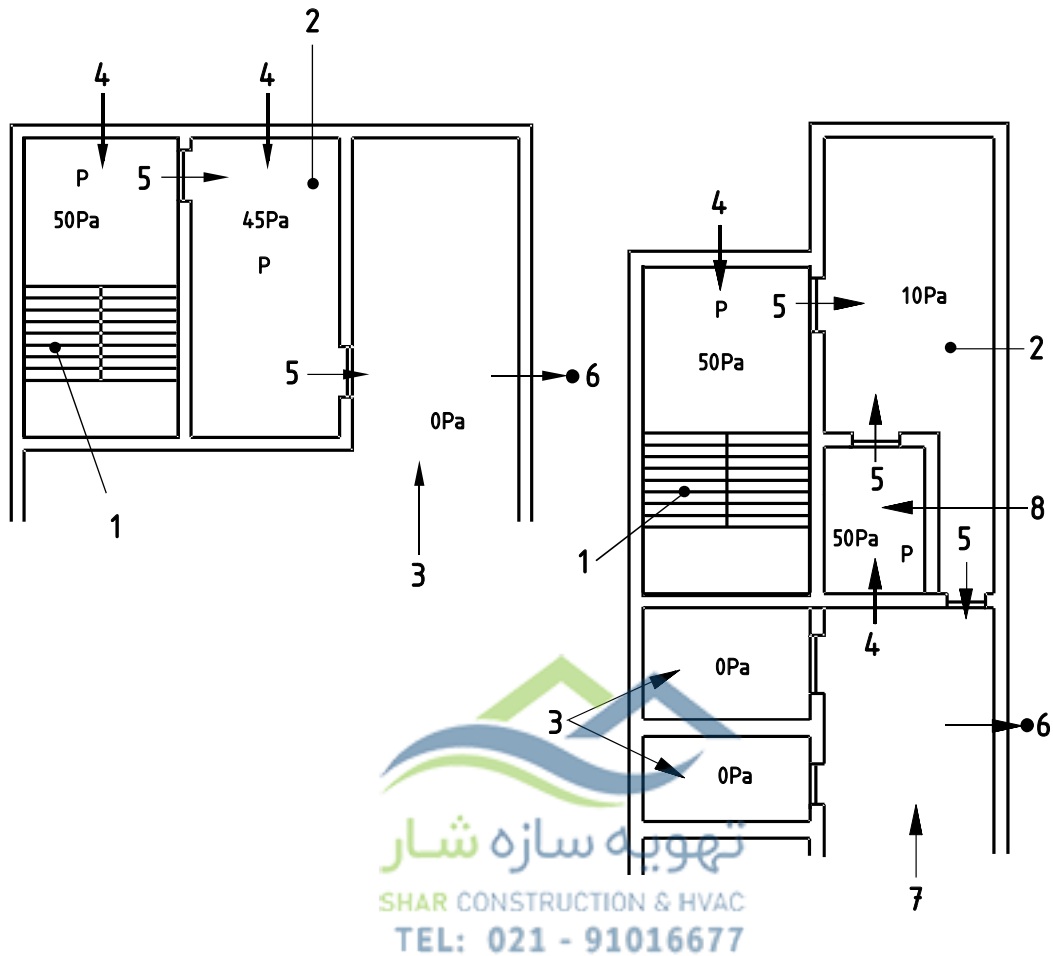

10a Pressurization to stairs and all associated lobbies

10b Pressurization to stairs and lift shaft

Key

- 1 Stair
- 2 Lobby
- 3 Accommodation
- 4 Supply air
- 5 Leakage path through doors, etc.
- 6 Air release path from building
- 7 Corridor
- 8 Lift

P denotes pressurized space. Encircled number denotes minimum design pressure differential, e.g. 50 (Pascals) relative to the accommodation, identified by 0

Figure 10 — Pressurization to stairs and all associated lobbies

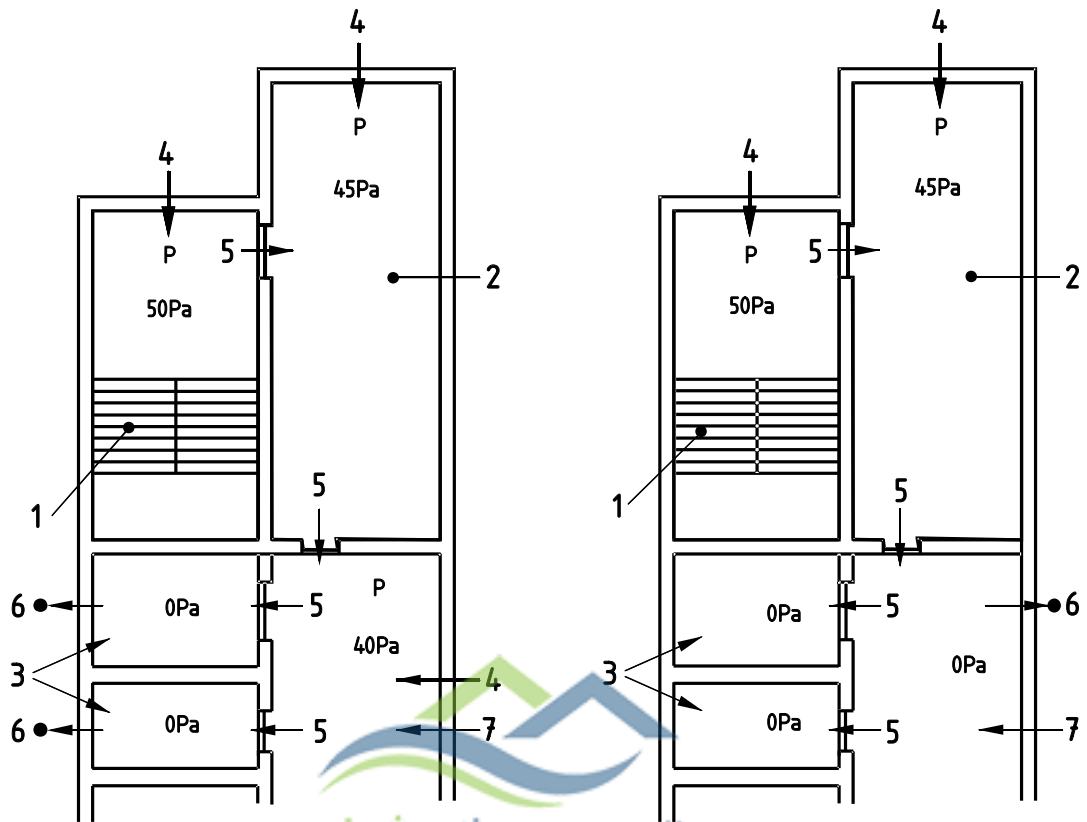

11 a) Pressurization to stairs associated lobbies and corridors

11 b) Pressurization to stairs and associated release from corridors

تعمیر سازه شار
SHAR CONSTRUCTION & HVAC
TEL: 021 - 91016677

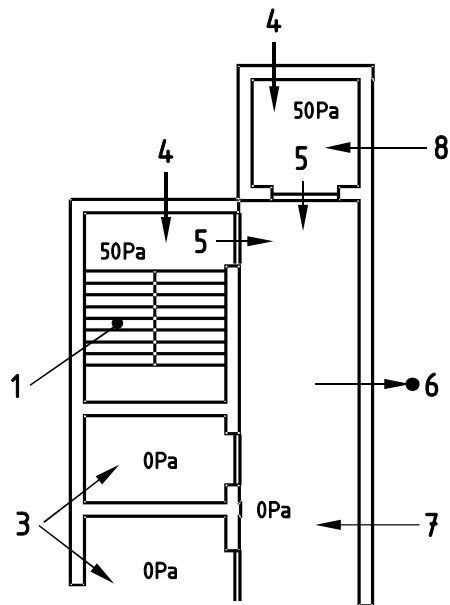

11 c) Pressurization to stairs lift wells and all associated lobbies

Key

- 1 Stair
- 2 Lobby
- 3 Accommodation
- 4 Supply air
- 5 Leakage path through doors, etc.
- 6 Air release path from building
- 7 Corridor
- 8 Lift



P denotes pressurized space denotes minimum design pressure differential, e.g. 50 (Pascals) relative to the accommodation, identified by 0

Figure 11 — Stair pressure differential system configurations

6.3 Pressurizing the stairwell and lobby, with air release from the corridor

6.3.1 General

If the lobby opens into a corridor that forms part of the horizontal escape route, it may be an advantage in certain systems to pressurize the stair and lobby, and release the air in the corridor (see Figure 11 b)).

6.3.2 Requirements for pressurizing the stairwell and lobby, with air release from the corridor

6.3.2.1 With all doors closed the pressure difference across the doors shall be as shown in Figure 11 b).

6.3.2.2 When smoke is detected, either:

- a) all systems pressurizing the stairwells and lobbies shall be activated simultaneously, or
- b) all stairwells and only the lobbies on the fire incident floor shall be pressurized whenever there is a fire alarm signal.

6.3.2.3 Arrangements shall be made to ensure that the corridor has adequate air release to outside air.

6.3.2.4 The arrangements shall comply with the appropriate class of system as defined in Clause 4.

6.4 Pressurizing the stairwell, lobby and corridor

6.4.1 General

If the lobby opens into a corridor that forms part of the protected escape route, the pressurization system may, with advantage, be extended to include the corridor and so take the smoke control right up to the door of the fire zone. However, if the corridor has many doors (or other leakage paths) the air supply needed may be large. The design aim shall be to ensure airflow from the stairwell, through the lobby, through the corridor to the external air, either directly or via the accommodation (see Figure 11 a)).

6.4.2 Requirements for the stairwell, lobby and corridor

6.4.2.1 The corridor shall be a protected corridor and shall have pressurizing air supplied from a duct separate from the lobby and stairwell supply.

6.4.2.2 With all doors closed, the pressure differences across doors between the corridor and the accommodation shall be as shown in Figure 11 a).

6.4.2.3 Arrangements shall be made to ensure that the corridor has adequate air release to the external air, via the accommodation.

6.4.2.4 When smoke is detected, either:

- a) all pressurized stairwells and pressurized lobbies on all storeys shall be pressurized simultaneously. Only the corridor on the fire affected storey need be pressurized, or
- b) all pressurized stairwells and only the lobbies and corridors on the fire incident floor shall be pressurized.

6.4.2.5 The arrangements shall comply with the appropriate class of system as defined in Clause 4.

6.5 Stairwell and lift shaft

6.5.1 General

If smoke enters an unpressurized lobby or corridor, a lift shaft forms a potential route for the spread of smoke from the fire storey to other storeys. By pressurizing the lift shaft it is possible to restrict the spread of smoke via the lift shaft to other storeys. The pressurization of the lift shaft may also be required for Class B systems (see Figure 11 c)).

6.5.2 Requirements for stairwell and lift shaft

6.5.2.1 Where the lift is accessed via an unpressurized lobby or corridor, the lift shaft shall be pressurized to the same level as the associated stairwell.

6.5.2.2 With all the doors closed the pressure differences across the doors between the lift shaft and the stairwell shall be as shown in Figure 11 c).

6.5.2.3 Arrangements shall be made to ensure that there is adequate air release from the corridor to external air.

6.5.2.4 When smoke is detected, all the pressurized stairwells and pressurized lift shafts shall be pressurized simultaneously.

6.5.2.5 The arrangements shall comply with the appropriate class of system as defined in Clause 4.

NOTE A lobby connected to a lift well or other shaft is still considered to be a simple lobby if all such shafts are pressurized independently.

6.6 Stairwells and corridors with air release from accommodation

6.6.1 General

Where the stairwells and corridor of any storey provides the means of escape from the accommodation to the stairwells, the stairwells and corridor may be pressurized as shown in Figure 12 a). This arrangement will carry the protection against smoke right up to the door into the accommodation.

6.6.2 Requirements for stairwells and corridors with air release from accommodation

6.6.2.1 With all doors closed, the pressure difference across the doors shall be as shown in Figure 12 a).

6.6.2.2 When smoke is detected, either:

- a) all pressurized stairs and pressurized corridors on all storeys shall be pressurized simultaneously, or
- b) all pressurized stairs and only the corridor on the fire incident floor shall be pressurized.

6.6.2.3 This arrangement shall be controlled by addressable dampers, etc.

6.6.2.4 The arrangements shall comply with the appropriate class of system as defined in Clause 4.

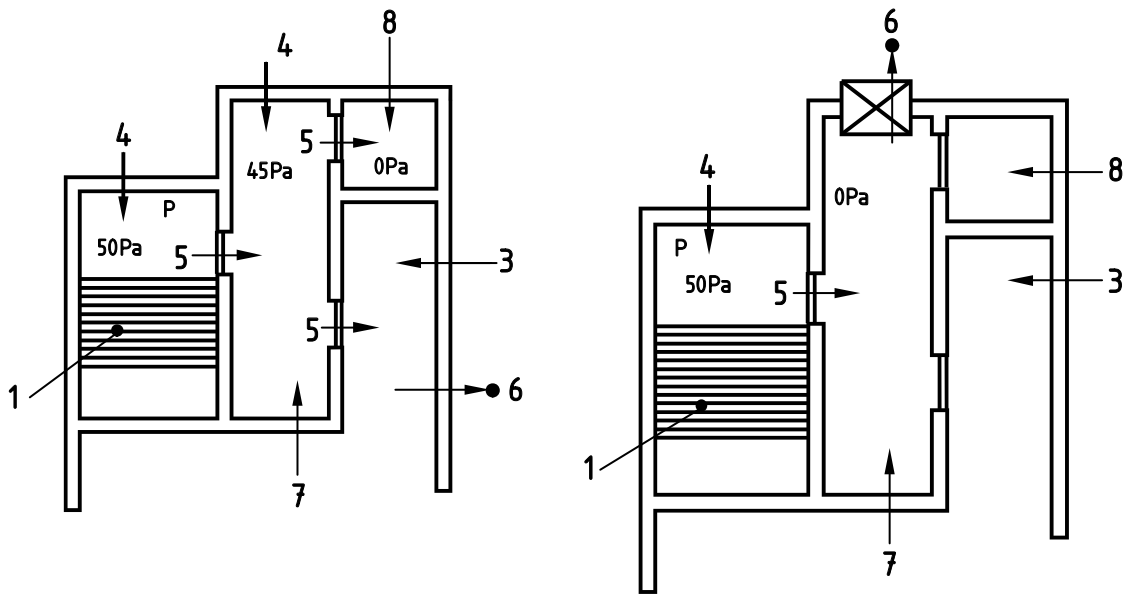

12 a) Pressurization to stairs and corridors

12 b) Pressurization to stairs and air release in corridors

Key

- 1 Stair
- 2 Corridors
- 3 Accommodation
- 4 Supply air
- 5 Leakage path through doors, etc.
- 6 Air release path from building
- 7 Corridor
- 8 Lift



P denotes pressurized space denotes minimum design pressure differential, e.g. 50 (Pascals) relative to the accommodation, identified by 0

Figure 12 — Stair pressure differential system configurations

6.7 Stairwells and air release from corridors/lobby

6.7.1 General

Where air release from the accommodation is not provided, the option of pressurizing the stairwells with air release from the lobby/corridor as shown in Figure 12 b) shall be used.

6.7.2 Requirements for stairwells and air release from corridors/lobby

6.7.2.1 With all the doors closed, the pressure difference across the doors shall be as shown in Figure 12 b).

6.7.2.2 When smoke is detected, systems pressurizing the stairwells shall be activated simultaneously.

6.7.2.3 Arrangements shall be made to ensure that the corridor/lobby has adequate air release to the external air.

6.7.2.4 The air release arrangement shall only operate on the fire incident floor.

6.7.2.5 The arrangements shall comply with the appropriate class of system as defined in Clause 4.

6.8 Stairwells, lobbies and lift shafts

6.8.1 General

A pressure differential system may be used to minimize the potential for the serious contamination of firefighting stairwells by smoke during fire service operations.

During firefighting operations it is necessary to open the door between the firefighting lobby and the accommodation to deal with a fully developed fire.

6.8.2 Requirements for stairwells, lobbies and lift shafts

6.8.2.1 With all the doors closed, the pressure difference across the doors shall be as shown in Figure 13.

6.8.2.2 All the pressurized stairwells, lobbies and lift shafts on all storeys shall be pressurized simultaneously upon operation of an automatic smoke detector or operated manually by the fire officer (see Clause 12).

6.8.2.3 The arrangements shall comply with a Class B system as defined in Clause 4.

6.8.2.4 The stairwells, lobbies and lift shaft shall all be pressurized separately to ensure that the contamination of smoke to each area is kept to a minimum.

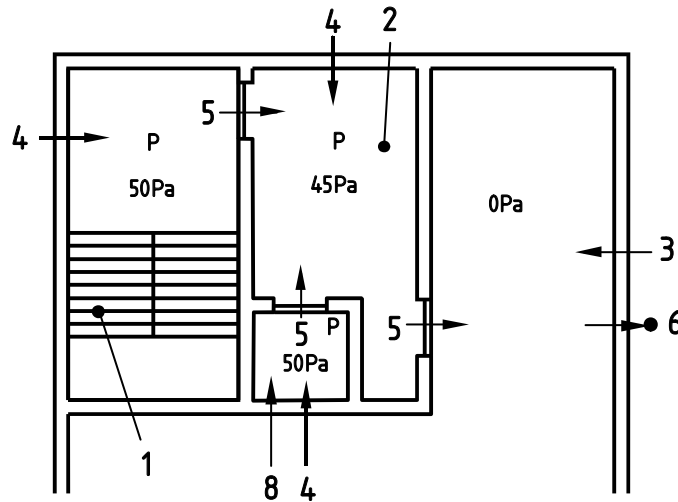

Key

- 1 Stair
- 2 Lobby
- 3 Accommodation
- 4 Supply air
- 5 Leakage path through doors, etc.
- 6 Air release path from building
- 8 Lift

P denotes pressurized space denotes minimum design pressure differential, e.g. 50 (Pascals) relative to the accommodation, identified by 0

Figure 13 — Pressurization to stairs lobbies and lift wells (these arrangements are provisions for firefighting)

7 Design procedures for pressurization systems

7.1 General

7.2 to 7.4 are intended to illustrate the general design principles involved in all classes of system and may be adapted to suit other applications.

Where a stair is intended for firefighting purposes it is more appropriate to carry out the firefighting design procedure before that for means of escape.

Information regarding air leakage areas for typical forms of construction is given in A.6.2. Guidance regarding the calculation of effective leakage areas for flow paths in series and in parallel is given in Clause 15.

7.2 Design for means of escape requirements

7.2.1 The effective leakage areas for the following flow paths at each storey shall be evaluated for the closed door scenario (see 15.2.1 and 15.2.2):

- a) from stairwell to simple lobby to accommodation;

EN 12101-6:2005 (E)

- b) from stairwell direct to the external air;
- c) from accommodation to the external air;
- d) from lift well direct to the external air;
- e) from lobby to accommodation.

In existing buildings the leakage areas will be highly dependent upon the quality of the workmanship and the nature of the structure, hence the actual leakage values may vary considerably from assumed design values. Effective leakage areas shall, if possible, be evaluated by an on-site airflow measurement.

7.2.2 The air leakage rate via each flow path from the pressurized shaft at the design pressurization level with all stairwell, lift and lobby doors closed (see Clause 15) shall be calculated (see 15.2.3 to 15.2.7).

7.2.3 All the air leakage rates shall be added together to give the theoretical air supply rate (see 15.2.8). To give the total required air supply rate, this value shall be multiplied by a factor of at least 1,5 to take account of uncertainties in identified leakage paths (see 15.2).

7.2.4 The air supply rate in accordance with the respective class of system shall be determined for the open door situation (see 4.2 to 4.6).

7.2.5 The total supply required with all the appropriate doors open according to the system class selected plus an allowance of 15 % for ductwork losses shall be calculated.

7.2.6 The required air flow rates for the closed and the open door conditions shall be compared, and the higher selected as the required total air supply rate.

7.2.7 The air release requirements shall be determined (see 5.3 and 15.2). Calculating the air release requirements is not necessary if the firefighting design procedure has previously been carried out.

7.2.8 The nominal overpressure relief required to relieve excess air supply from the pressurized space shall be calculated (see 5.4 and 15.2).

7.2.9 The lift shaft shall not require overpressure relief vents if the supply system is initially set up so as to achieve the required pressurization level with all doors closed.

7.3 Design for firefighting

7.3.1 General

A stairwell that serves a firefighting shaft may require a greater air supply rate and greater air relief provisions from the accommodation than a stairwell used only for means of escape.

In order to simplify the calculation procedure, it may be assumed that there is no interaction between the stairwell and the lift pressure differential systems (this will tend to give an overestimate of the required total air supply rate to the stairwell because it does not take account of the additional air flow between the lift and the stairwell).

The following procedures are intended to establish the required air supply with the final exit door open, the stairwell and lobby doors on the fire floor open and adjacent storey door or doors open (as identified in 4.3).

7.3.2 Design for firefighting requirements

7.3.2.1 The air leakage rate/air supply required shall be calculated in accordance with 7.2.1.

7.3.2.2 The required air flow rate through the open lobby-to-accommodation door to provide an air velocity of 2 m/s, assuming the lobby-to-accommodation door is fully open, shall be calculated (plus 15 % allowance for ductwork losses if applicable).

7.3.2.3 For double-leaf doorsets the effective area of the open door shall be assumed to be a single leaf of the open doorway.

7.3.2.4 The pressure differential necessary to develop the required flow velocity of 2 m/s via the flow path from stairwell to lobby to accommodation to external air shall be calculated as described in Clause 15.

7.3.2.5 Using the stairwell pressure calculated above, the air flow required to maintain this pressure with the final exit door open shall be estimated, taking into account all of the leakage paths from the shaft at this design pressure (see Clause 15). The anticipated leakage via all paths other than the open doors shall be multiplied by a factor of at least 1,5 to take account of uncertainties in identified leakage paths.

7.3.2.6 The higher value of the supply air rate required for firefighting purposes and that required for the means of escape shall be selected as representing the required total air supply rate for design purposes (see Clause 15).

7.3.2.7 The air release capacity required on the fire floor, also the air release arrangements (see Clause 15) which shall be provided on all storeys, shall be calculated.

7.3.2.8 If the total air supply rate required for firefighting purposes is greater than that for the means of escape then the size of the stairwell shaft pressure relief vent shall be recalculated.

7.4 Additional aspects of pressurization of protected escape routes

7.4.1 General

Evacuation of the fire-affected storey needs to occur within the early stages of fire development and before conditions within the accommodation become untenable, making access to the protected escape routes impossible. During this initial period the potential for contamination of the protected routes is small. Before conditions on the fire storey become untenable the escape process from that storey ought to have been completed and the storey exit doors closed. Consequently, there is no need for the pressure differential system to hold back smoke from a fully developed fire at a door, as long as the air flow is sufficient to hold back smoke from the fire floor whilst persons are escaping.

Following evacuation of the fire-affected storey the fire may continue to develop with the potential to induce smoke flow into the stairwell via gaps around stairwell and lobby doors. It is therefore important to ensure that a positive pressure is maintained within the stairwell for the full duration of the evacuation process.

However, during this stage the final exit from the stairwell is likely to be in use, producing a loss of pressurizing air and hence tending to reduce the pressure in the stairwell, and it is necessary to take account of this when calculating the air supply.

The design conditions for stairwell pressure differential systems are shown in Figures 9 a), 9 b), 10, 11 a), 11 b), 11 c), 12 a), 12 b), 13, 14, 15 and 16.

7.4.2 Pressurization of protected escape routes, additional requirements

7.4.2.1 The protected escape routes shall be constructed in accordance with the recommendations of the appropriate national provisions valid in the country of use, where applicable.

7.4.2.2 All doors into the pressurized space shall be fitted with a self-closing device.

7.4.2.3 The maximum force required to open any door within the escape route shall in no circumstances exceed 100 N, applied at the door handle.

EN 12101-6:2005 (E)

NOTE 1 The corresponding maximum pressure differential across the door should be determined using the procedure in Clause 15, as a function of the door configuration. The force required to overcome the door closer will often not be known at a preliminary design stage and a maximum pressure differential of 60 Pa may be utilised for design purposes.

NOTE 2 The force that can be exerted to open a door will be limited by the friction between the shoes and the floor and it may be necessary to avoid having slippery floor surfaces near doors opening into pressurized spaces, particularly in buildings in which there are very young, elderly or infirmed persons.

7.4.2.4 Doors opening out of the pressurized space, other than final exit doors, shall have a self closer that can keep the door shut against the pressure.

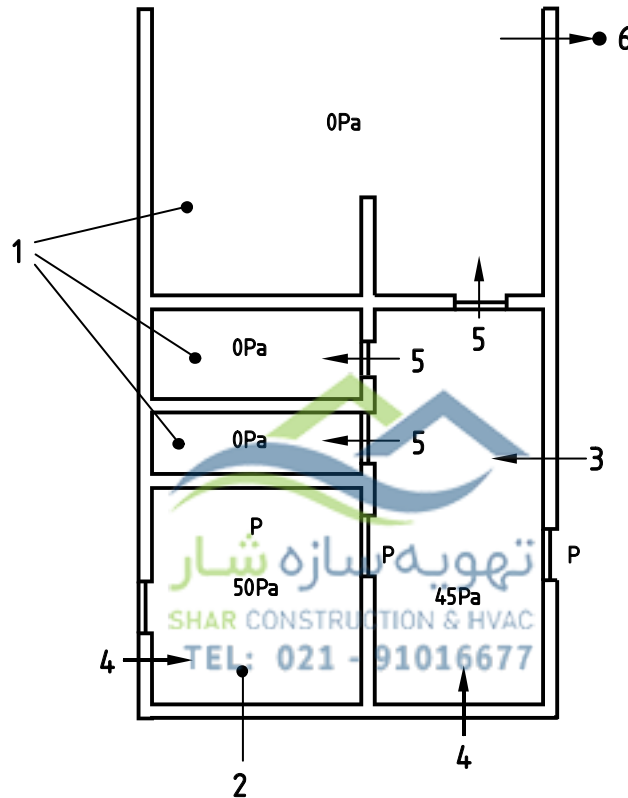

Key

- 1 Accommodation
- 2 Fire control centre
- 3 Corridor
- 4 Supply air
- 5 Leakage path through doors, etc.
- 6 Air release path from building

P denotes pressurized space denotes minimum design pressure differential, e.g. 50 (Pascals) relative to the accommodation, identified by 0

Figure 14 — Pressurization to Fire Control Centres, e.g. shopping malls or phased evacuation from complex buildings

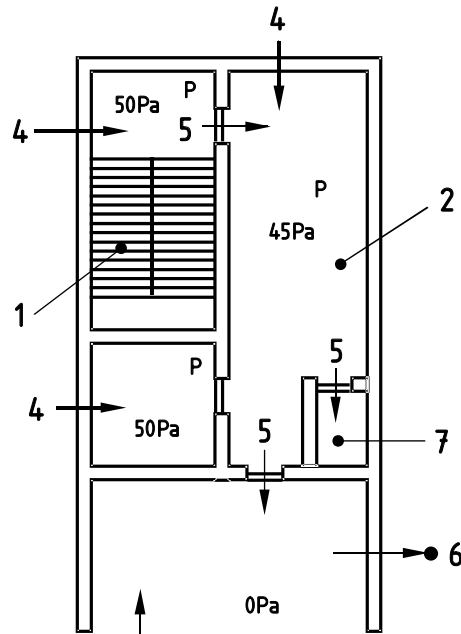

Key

- 1 Stair
- 2 Lobby and refuge lobby
- 3 Accommodation
- 4 Supply air
- 5 Leakage path through doors, etc.
- 6 Air release path from building
- 7 Lift

P denotes pressurized space denotes minimum design pressure differential, e.g. 50 (Pascals) relative to the accommodation, identified by 0



Figure 15 — Pressurization to refuge

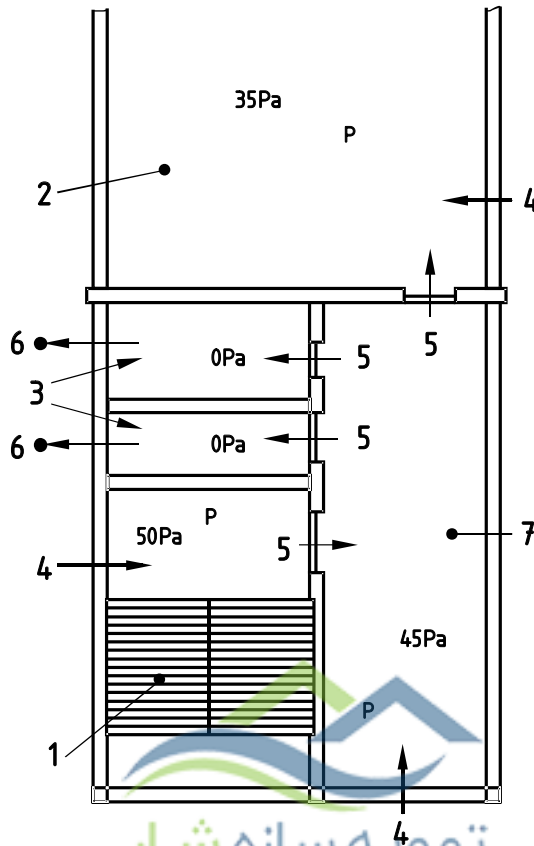

Key

- 1 Stair
- 2 Computer or medical room
- 3 Accommodation
- 4 Supply air
- 5 Leakage path through doors, etc.
- 6 Air release path from building
- 7 Corridor

P denotes pressurized space denotes minimum design pressure differential, e.g. 50 (Pascals) relative to the accommodation, identified by 0

Figure 16 — Pressurization to computer suites and medical facilities

8 Pressurization of refuges and other spaces

8.1 General

It may be necessary to pressurize refuges and other protected spaces, e.g. fire control rooms, to provide protection to occupants from fire and smoke when there is a need for them to remain in the building for a period of time after the start of a fire.

This protection is normally in the form of a specific room close to the means of escape staircase or forming part of a route to a storey exit, constructed of fire-resisting materials (including fire-resisting doors with effective self-closing devices), in accordance with national provisions valid in the place of use of the system. Refer to Figures 14 and 15 for typical plan layouts.

If buildings contain spaces such as computer suites or medical facilities that are pressurized for reasons other than fire, consideration shall be given to protecting the pressurized escape route from the effects of fire in these pressurized spaces. Refer to Figure 16 for a typical floor layout.

8.2 Requirements for refuges and other spaces

8.2.1 Where refuges are designed into the building, the fire-resisting protection given to that space shall comply with the national provisions valid in the place of use of the system, where applicable.

8.2.2 The pressure difference between the refuge or protected space and the accommodation shall be not less than 50 Pa.

8.2.3 The pressurized refuge or other space shall not be connected to an unpressurized stair, and the pressure in the refuge shall not be greater than, or more than 5 Pa less than, the pressurized stair, for the design pressure with all doors closed (see Figures 14 and 15).

8.2.4 In cases where the refuge forms part of the protected escape route, for example a lobby area in a lobby protected building, the lobby shall be designed so that it is of sufficient capacity for the purpose of use.

8.2.5 If there is more than one pressurized system operating on any one storey, then account shall be taken of the total leakage paths with all systems running simultaneously.

8.2.6 The refuge area shall be sufficient for the purpose of use.

8.2.7 Where the refuge area forms part of the same undivided space as an escape route, its presence shall not impede the normal use of that escape route.

8.2.8 If a pressurized escape route is directly connected to a pressurized space that does not form part of the escape route, then the design pressure in the escape route shall be at least 10 Pa greater than the pressurized space of any room pressurized for non-fire purposes, e.g. medical rooms or computer suites or any room not pressurized for fire (see Figure 16).

9 Depressurization

9.1 General

The objective of a depressurization system is to achieve the same protection at the doorway between the depressurized space (e.g. a basement) and the protected space (e.g. a stairwell) as would be achieved by pressurizing the protected space. It is important to note that there is no protection of any part of an escape route within the depressurized space itself, which may be entirely filled with smoke, or may even be fully involved in a fire. This constitutes a fundamental difference between depressurization and smoke exhaust ventilation. To be effective, each depressurized space shall be bounded on all sides by fire-resisting

EN 12101-6:2005 (E)

constructions, because any loss of integrity would result in equalization of pressure between the depressurization zone and external air. However, in compartmented buildings it may be possible to depressurize individual spaces. See Figure 17 for the typical features of a depressurization system.

The most appropriate use of depressurization systems is likely to be in basement spaces, see Figure 18 for layout.

9.2 Depressurization requirements

9.2.1 Inlets from external air to the protected space shall be provided to ensure replacement airflow from the protected space to the depressurized space.

9.2.2 The replacement air intake shall be sited so that the air being drawn in to the protected space is not contaminated by the smoke produced by the fire.

9.2.3 The system shall consist of exhaust fans and if necessary ductwork to remove hot gases and smoke produced by the fire within the depressurization zone to the outside of the building.

9.2.4 Air inlets shall be provided for the necessary replacement air required to allow the pressure differential to develop across the closed doors and to meet the airflow velocities through the open door into the fire zone, initially for means of escape and/or subsequently for firefighting purposes.

9.2.5 The outlets of the exhaust ductwork shall be in such positions that smoke does not threaten the safety of occupants and firefighters or persons outside the building and does not contribute to external fire spread.

9.2.6 Depressurized zones shall be bounded on all sides (including the floor slab above and below) by constructions having fire-resistance at least equal to that required for the protected space.

9.2.7 All doors to the depressurization zone shall be self-closing.

9.2.8 The extraction ductwork from the depressurization zone shall meet the requirements for fire-resistance for a period at least equal to the highest period of fire-resistance through which the ductwork passes, when tested and classified in accordance with prEN 13501-3.

9.2.9 The extraction fan from the depressurization zone shall be capable of handling smoke at a temperature of 1 000 °C for unsprinklered buildings, or 300 °C for sprinklered buildings, when tested and classified in accordance with prEN 13501-4.

9.2.10 With all doors closed, the extraction rate of smoke and hot gases from the depressurization zone shall be capable of maintaining a pressure differential not less than that given in Clause 4 for the appropriate system class and, where relevant, the open door airflow criterion.

9.3 Design procedures for depressurization systems

9.3.1 General

Depressurization systems can be configured to cover means of escape in case of fire and fire fighting procedures.

The design procedure will be the same for both systems, except that where the design is for fire fighting the exhaust volume flow rate will be increased to take account of the later stage of development of the fire.

9.3.2 Design procedure for means of escape requirements

The basic design procedures shall be as follows:

9.3.2.1 Evaluate the leakage paths from the exterior of the building into the depressurized space, ignoring the doors being protected by the design.

9.3.2.2 Calculate the required exhaust volume flow rate to obtain the desired airspeed of 0,75 m/s through the open doors between the protected spaces and the depressurized space. Calculate the pressure difference across those same doors to maintain this airspeed. Ensure that the resistance of the leakage paths from the exterior of the building to the protected spaces is included in the calculation.

NOTE If the final exit door is open, the flow resistances of these leakage paths will be sufficiently low to be ignored.

9.3.2.3 Calculate the additional volume flow rate drawn through the leakage paths, identified by the pressure difference across the open doors between the protected spaces and the depressurized space.

9.3.2.4 Calculate the exhaust fan duty required to maintain this airspeed, i.e. the sum of the volume flow rates identified in 9.3.2.2 and 9.3.2.3.

9.3.2.5 Calculate the exhaust fan duty required to provide the minimum pressure difference of 50 Pa \pm 10 % across the closed door(s) between the protected spaces and the depressurized space, based on the leakage paths identified in 9.3.2.1.

Usually this fan duty will be less than that identified in 9.3.2.4. If it is greater, then this fan duty shall be specified for the exhaust fan.

9.3.2.6 The pressure drop which will be exerted across the closed door into the depressurized space shall be calculated, taking account of the following:

- a) the effects of any ductwork associated with those fans;
- b) the leakage areas identified in 9.3.2.1;
- c) the size of fan identified in 9.3.2.4 and 9.3.2.5, whichever is the larger.

9.3.2.7 If this pressure difference would cause a door opening force at the door handle to exceed 100 N, pressure relief devices shall be installed.

9.3.3 Design procedure for firefighting requirements

The design procedures for the protection of a firefighting shaft are the same as for the protection of a protected stair for means of escape, except for the following:

9.3.3.1 When calculating the required exhaust volume flow rate, an airspeed of 2 m/s shall be required through the open doors between the firefighting shaft and the depressurized space.

9.3.3.2 Then calculate the pressure difference across those same doors to maintain this airspeed.

Ensure that the effect of the leakage paths from the exterior of the building to the protected/depressurised spaces is included in the calculation.

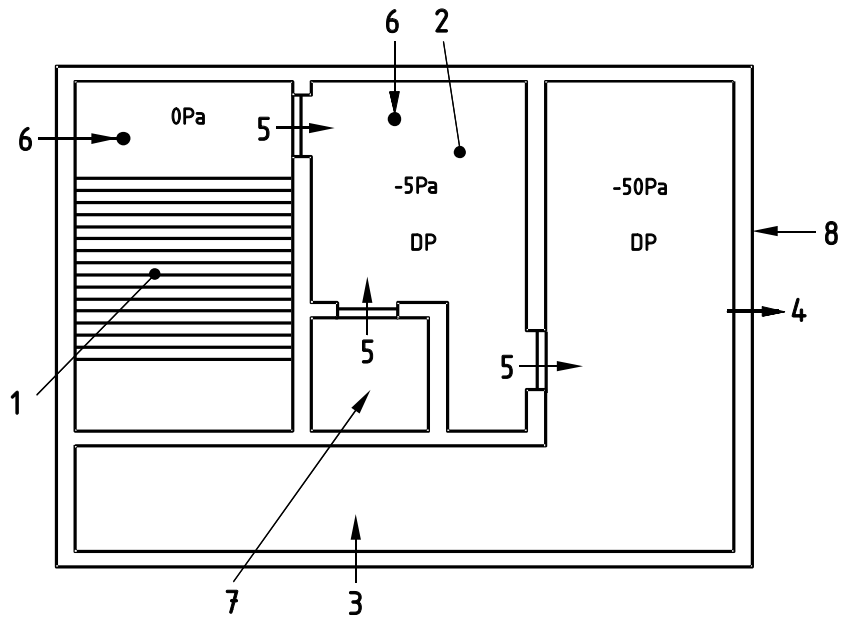

Key

- 1 Stair
- 2 Lobby
- 3 Accommodation
- 4 Exhaust (depressurize)
- 5 Leakage path through doors, etc.
- 6 Make up air to building
- 7 Lift
- 8 Fire resisting construction



DP denotes depressurized space denotes minimum design pressure differential, e.g. 50 (Pascals) relative to accommodation, identified by 0

Figure 17 — De-pressurization of basements or of other spaces with no external windows

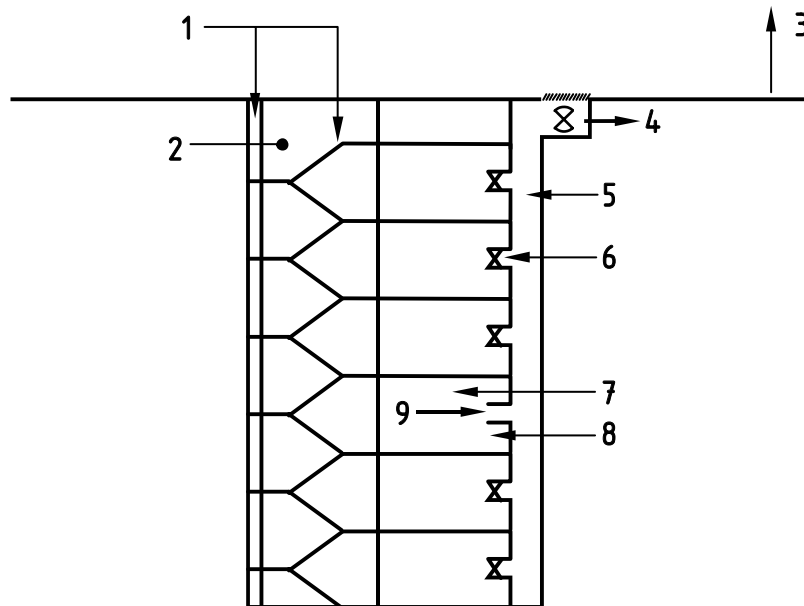
**Key**

- 1 Make up air via shaft or protected space
- 2 Protected space
- 3 Ground floor
- 4 De-pressurization fan
- 5 Extract ductwork
- 6 Smoke detector operated fire dampers
- 7 Fire zone
- 8 External leakage
- 9 Open damper on fire floor



Figure 18 — De-pressurization in basements

10 Interaction with other fire protection systems and other building systems

10.1 Fire detection systems

10.1.1 General

Pressure differential systems are designed to be triggered automatically by smoke detection systems. The detection system shall be capable of providing signals to the associated control panels so that the system becomes operative as early as possible in the fire growth period. These signals shall allow the pressure differential system in the fire zone area to operate as required on the actuation of the fire detection system.

10.1.2 Fire protection systems requirements

10.1.2.1 The fire detection system shall comply with provisions valid in the country of use.

10.1.2.2 The fire detection system shall be capable of locating the fire so that it allows the pressure differential system in fire zone areas to be activated as required by the design. See 11.2.3 for further data on the initiating time.

10.2 Heating, ventilation and air conditioning (HVAC) systems

10.2.1 General

10.2.1.1 The primary purpose of a pressure differential system is to establish an airflow and pressure differential pattern in the building that will limit the spread of smoke towards or past the doors onto the escape route being protected.

10.2.1.2 An HVAC system designed to maintain acceptable environmental conditions shall therefore follow the airflow patterns identified in 10.2.1.1, e.g. away from escape routes. This will ensure that at the early stages of a fire, prior to the establishment of the designed pressure differentials of the system, the escape routes and other sections of the smoke movement strategy are not adversely affected.

10.2.1.3 The operation of the HVAC system in a fire emergency shall be designed so that it does not adversely affect the pressure differential strategy. If there is a possibility of the HVAC system affecting the pressure differential system then the HVAC system shall be shut down to prevent the smoke movement penetrating other interconnected spaces.

10.2.2 HVAC system requirements

10.2.2.1 In the event of a fire, either the HVAC system shall be stopped automatically by a signal from the fire alarm system or it shall be constructed as a smoke exhaust system according to prEN 12101-4 and only remain operational under the following conditions:

- a) the signal to activate the emergency action is the same as that which initiates the pressure differential system;
- b) re-circulation of air is stopped and all vitiated air exhausted to atmosphere;
- c) supply/exhaust air systems from the accommodation on the fire storey is switched to total exhaust rate, with the ductwork transporting the gases having a fire resistance which complies with the national provisions valid in the place of use of the system;
- d) the components used in fixing the ductwork to the structure shall support the structure for at least the same time period as that of the rating of the ductwork;
- e) air supply to all floor levels shall be stopped;
- f) the positions of the exhaust outlets shall maintain airflow away from storey exits.

10.2.2.2 To prevent smoke movement from one fire compartment to another through HVAC ductwork, smoke dampers shall meet the integrity E class of the boundary through which it passes. The operations of these dampers to go into the fire operational mode shall be via a signal from the automatic fire detection system.

10.2.2.3 Smoke control dampers shall be capable of being powered open and closed in the fire mode. Also refer to Clause 11 for further information.

10.3 Computerised control systems

10.3.1 General

Computerised control systems shall be used to control the various operational functions of a pressure differential system, and will rely on the use of specific software to carry out the modes of operations required of that system in accordance with prEN 12101-9.

Consideration shall be given to protection of signalling system wiring.

10.3.2 Computerised control systems requirements

10.3.2.1 Where computerised control systems are used as part of the operational requirements of a pressure differential system, then any changes to the software controlling the fire safety functions shall not affect the operation of the pressure differential system.

10.3.2.2 When changes are made to the software or associated computer system, a full check of the pressure differential system shall be carried out to confirm the continual functioning of the system.

10.3.2.3 A comprehensive description of the control software shall be provided to the building owner and/or his site agent by the system designer, together with documentation of all changes made to the system after installation.

10.3.2.4 Signalling systems providing the information to and from the computerised control centre shall be protected from the effects of fire for a period complying with national provisions valid in the place of use of the system. Also refer to Clause 12 for further information.

10.4 Public address and voice alarm systems

10.4.1 General

These systems are used to give information and action messages to occupants within the building in case of fire, and the required levels of audibility will be determined by national provisions valid in the place of use of the system.

10.4.2 Requirements for public address and voice alarm systems

Sound levels of public address and voice alarm systems shall be adjusted so that when the pressure differential fans are activated in the event of a fire, the resulting messages are clearly audible and intelligible above the noise produced by the pressure differential system (e.g. fans).

11 Installation and equipment (including components)

11.1 Introduction

The pressure differential system equipment consists of fan(s), distribution ductwork, balancing and fire rated dampers and appropriate pressure release vents.

Where a ventilation system (HVAC) is used to form part of a pressurization or a depressurization system, the components shall comply with the requirements of this clause.

To ensure that the system operates satisfactorily in the event of an emergency there shall be provision for an alternative power supply and stand-by equipment, e.g. fan(s).

EN 12101-6:2005 (E)

The equipment needed to create a pressure differential between the protected space and the accommodation consists of the equipment listed in the following sub-clauses.

11.2 Fans and drive mechanism

11.2.1 General

The fan performance is calculated by summation of the leakage from all the identifiable leakage paths in the pressurized zones. It is vitally important that the architect and builder agree with the installing engineer, with full regard to prevailing national regulatory requirements, what is expected from the escape route construction.

It is often difficult to identify all leakage paths likely to occur where solid construction encloses the protected space. The fan performance shall be at least 1,5 times larger than that calculated for the predicted leakages, not including open door scenarios, in order to allow for the unidentified leakages. Where materials and construction techniques that may produce significant leakage, e.g. plasterboard walls and false ceilings, are used, the factor of 1,5 may need to be increased, following consultation with the architect and builder.

When selecting a fan for the required performance, account shall be taken of the temperature and time for which the system is required to work (see 9.3.2.4 and 9.3.2.5 for air release and depressurization systems).

NOTE Where there is doubt as to the air tightness of an existing building construction, and where refurbishment is taking place, it may be practical to assess the leakage areas using a calibrated portable fan prior to specifying the fan performance.

11.2.2 Requirements for fans and drive mechanism

The fan performance shall be assessed as follows:

11.2.2.1 The volume flow rate for the closed door scenario shall not be less than the calculated air supply to or from all pressurized or depressurized spaces served by the particular fan(s) plus an allowance of 50 % for unidentified leakage paths and 15 % for probable ductwork leakage.

11.2.2.2 The volume flow rate for the open door scenario shall not be less than the calculated air supply to or from all pressurized or depressurized spaces served by the particular fan(s) plus 15 % for probable ductwork leakage.

11.2.2.3 The fan shall be able to supply the volume flow rates of air specified in 11.2.2.1 and 11.2.2.2 at a high enough pressure to achieve the necessary pressure differentials specified in this document (the emergency pressurization level) while overcoming all pressure losses in the air supply duct work.

Account shall be taken of the potential wind pressures on the suction side of the fan.

11.2.2.4 The operating conditions of the depressurization fans shall be continuous operation for the appropriate period of time and temperature specified.

11.2.2.5 The operating conditions of the pressurization fans shall be rated for continuous operation under expected ambient conditions.

11.2.2.6 To control the pressure differential, over-pressure release vents shall be fitted in the pressurized spaces and shall open directly to the external air, or dampers can be fitted into a duct bypassing the fan, or there can be a rotational speed control on the fan.

NOTE Where pressure differential fan(s) serve more than one pressurized space concurrently, it may be necessary to interpose volume control dampers to ensure that when high leakage occurs from an area, e.g. when doors are open or construction failure occurs, some protection continues in the remaining areas.

11.3 Air release

11.3.1 General

An essential feature of a pressurization/depressurization system is the provision of a low resistance path to external air. By providing such a path to external air the desired pressure differential between the accommodation and the protected space can be maintained, thus excluding smoke from the protected space. If there is insufficient leakage to external air from the accommodation, an adequate pressure differential and/or air velocity will not be maintained. In a similar way, it is an essential feature of a depressurization system that clean ambient air from the exterior shall be able to enter the protected space.

The methods of air release are:

- a) external wall vents, which include automatically openable windows and trickle ventilators;
- b) vertical shaft air release, where vents in accommodation spaces connect to a common vertical shaft which releases smoke at the top of the building;
- c) mechanical extraction, other than depressurization systems, which consists of fan(s) and ductwork, either dedicated to the removal of air/smoke from the spaces affected by fire or an HVAC system suitably designed and controlled to fulfil this function.

11.3.2 Air release requirements

11.3.2.1 The air release system shall either be in continuous operation, e.g. trickle ventilators, or be automatically activated ventilators (e.g. openable windows) or release dampers, ready to open on a signal from the smoke control system.

11.3.2.2 Where the actuation of the air release system is automatic, it shall be controlled in such a way that it only operates in the fire zone.

NOTE Arrangements for the control of a powered automatic air release system are outlined in 10.3.2.

11.3.2.3 The air release system shall be such that in normal operation or in the fail safe mode there is no movement of smoke between different fire compartments.

11.3.2.4 Where the air release is achieved by mechanical extraction, the fan(s) and ductwork shall operate continuously at the appropriate temperature and period of time listed in Table 7.

11.3.2.5 If the discharge point(s) of the air release system are at the same level as the air intakes, they shall be installed in accordance with 11.8.2.

11.3.2.6 Inlet air to the protected spaces in a depressurization system may be provided through devices which comply with 11.3.2.1. There is no need for such devices to be able to withstand high temperatures as listed in Table 7.

Table 7 — Minimum temperature/time design criteria for fan(s) and HVAC ductwork used for air/smoke release

Does the building contain:				Minimum temperature criteria for a time equivalent to the fire resistant construction for the protected space
Means of escape	Fire-fighting	Sprinklers	No sprinklers	
Yes		Yes		300 °C
Yes			Yes	600 °C
	Yes	Yes		400 °C
	Yes		Yes	600 °C

NOTE The minimum temperature/time design criteria for fans and ductwork for depressurization system should be 1 000 °C for a period at least equal to that required for the protected space (see 9.2.8 and 9.2.9).

11.3.2.7 The temperature rating of 300 °C for sprinklered buildings shall be increased to 400 °C if there is only one exhaust point per compartment.

11.3.2.8 The criteria for the temperature rating of 300 °C shall be for when there is a minimum of two exhaust/relieving points per compartment, and the exhaust points shall be separated by a minimum distance of 3 m.

SHAR CONSTRUCTION & HVAC
TEL: 021 - 91016677

11.4 Actuation and control

11.4.1 General

The purpose of a pressure differential system is to prevent the ingress of smoke into a protected space. Therefore automatic smoke detectors shall be used to actuate the pressure differential system equipment, because a considerable quantity of smoke may be produced in the early stage of a fire before a heat detection, sprinkler or other extinguishing system is initiated. However, the transition from the means of escape mode to the firefighting mode in dual purpose systems can be by manual operation.

11.4.2 Requirements for actuation and control

11.4.2.1 The pressure differential system shall be actuated automatically by point type smoke detectors mounted at high level in the accommodation adjacent to the doors leading to the protected space at each storey served by the system. The smoke detectors shall be located as recommended by national provisions valid in the place of use of the system.

In Class A systems smoke detectors shall be sited in the common lobbies/corridors (where these are provided).

The smoke detectors may be part of the fire detection system protecting the building or may be dedicated to the pressure differential system.

11.4.2.2 In systems where the operation of the air release system is automatic, its actuation shall be by the same signal that actuates the rest of the system.

11.4.2.3 Systems shall be operational within 60 s of detection of smoke.

11.4.2.4 Where national provisions valid in the place of use of the system require/permit dual operating systems for protection of the shafts for means of escape and as access for firefighting, then the following will be acceptable:

- a) the transition between means of escape mode and fire fighting mode shall be manual;
- b) the switch to change over from one mode to another shall be located at the fire fighting access level, and/or adjacent to the fire fighting lift switch, if a fire fighting lift is provided;
- c) by making the change to fire fighting mode, there shall be no detrimental effect to the means of escape mode.

11.4.2.5 Manual system-override switches for the pressurization system shall be located at the following locations:

- a) the building services plant room and the pressure differential system equipment plant room (if separate), and
- b) near the building entrance at a location agreed with the regulatory authority.

The switches, listed in 11.4.2.4 and where situated in an area accessible by members of the public, and in 11.4.2.5 b), shall be protected from physical interference by unauthorised people.

11.4.2.6 The switches listed in 11.4.2.5 shall be locked in the 'on' position when operated, and shall be so constructed that they may only be returned to the 'off' position by authorised personnel (e.g. by keyholders, or using a coded lock).

11.4.2.7 Where a dual operating system is not permitted for firefighting purposes, the system shall automatically enter the firefighting mode on starting up.

11.5 Overpressure relief

11.5.1 General

The design of pressurization systems according to this document involves evaluating the required airflow under two different conditions, i.e. all doors closed and with selected doors open. In most circumstances the airflow requirement with doors open will be greater than with all doors closed. Fans supplying air to meet the former condition can raise the pressure excessively in the latter condition.

If excessive pressures are allowed to develop in the protected space it may become difficult or impossible to open doors into the space.

To prevent the build up of excessive pressures, either counter balanced flap valves or systems controlled by pressure sensors shall be used to provide for the release of excess pressurizing air from the protected space.

11.5.2 Overpressure relief requirements

11.5.2.1 The overpressure release vent area shall be closed by a counter-balanced flap valve so designed that it will only open when the pressure exceeds the design pressure, or by another device having the same effect, where sub-devices comply with 11.5.2.3, except where variable supply fans complying with 11.5.2.4 are employed to prevent excessive overpressures.

EN 12101-6:2005 (E)

11.5.2.2 Overpressure relief vents shall discharge either directly or via appropriate ductwork to external air and not into the accommodation via an unprotected flow path. For Class F systems, if the overpressure relief vent discharges into the accommodation, the penetration of the fire-resisting barrier shall be protected by an automatically self closing fire damper classified in accordance with prEN 13501-3 and only operated by a temperature device.

11.5.2.3 The overpressure release vent shall be sized so that it is capable of discharging the total excess airflow. This is determined by subtracting the total air leakage from the shaft with all doors closed from the total required airflow rate under the most onerous air supply conditions (see Clause 15).

11.5.2.4 Variable supply fans or dampers controlled by pressure sensors shall not be used unless the system can achieve over 90 % of the new volumetric requirements within 3 s of a door being opened or closed.

11.6 Electrical power supplies (primary and secondary)

11.6.1 General

Electrical power supplies (primary & secondary) shall be in accordance with prEN 12101-10.

All electrical installations shall be installed, and periodically inspected and tested (with necessary maintenance carried out), by qualified electrical engineers.

All primary and secondary electrical supplies to:

- a) pressure differential system supply fans and any associated relief air path equipment;
- b) depressurization fans and any associated supply make-up air equipment
- c) fire alarm control systems and damper control systems, etc.,

need to be derived from the point at which the electrical supply enters the building, so that the failure of other equipment does not render the installations inoperative. Since it is not possible to determine where a fire may start, all power supplies and their associated control equipment back to the supply intake position, including cables, shall be regarded as being within the hazard/risk area.

To reduce the risk of the loss of electrical supply in a fire, a secondary power supply is considered essential. A secondary supply is required from a generator or a separate substation, which is of sufficient capacity to maintain supplies to the life safety and fire protection installations, including smoke control systems, systems using pressure differentials and ancillary equipment.

11.6.2 Electrical requirements

11.6.2.1 Requirements for power supplies for pressure differential systems

The power supply shall be designed to supply the pressure differential system for the designed flow rate and operating parameters.

The power supply to the pressure differential system shall be available for the time that the class of system is required to operate.

Electrical power shall be provided by three means:

- a) electrical public utility, and
- b) secondary/backup power supply (generating plant), or
- c) separate substations.

11.6.2.2 Requirements for generating plant used as secondary/backup power

11.6.2.2.1 The generating plant shall comply with prEN 12101-10.

11.6.2.2.2 The secondary power supply shall work in an area at normal room temperature.

11.6.2.2.3 Going from stand-by position (generating plant not working) to safety position (generating plant working) shall be automatic when the electrical supply from the public utility is not available to the pressure differential system. Return to the stand-by position shall also be automatic when the electrical supply from the public utility is restored, provided that there is no fire condition signalled from the fire detection system.

11.6.2.2.4 The equipment shall be protected against short-circuits.

11.6.2.2.5 Stand-by and safety positions shall be indicated on the control board.

11.6.2.2.6 The backup electrical power supply to the pressure differential system shall be independent of the primary electrical supply to the remainder of the construction works.

11.6.2.2.7 Each power supply shall be marked in accordance with prEN 12101-10.

11.6.3 Requirements for electrical cables

Electrical cables for the pressure differential systems shall comply with the following:

- a) fire-resisting cables meeting the temperature and time criteria in accordance with Table 7 or
- b) enclosed with fire-resisting construction, or installed external to the building where the cables cannot be endangered by fire, and
- c) cables protected from fire shall comply with the classification temperature/time of the component that they serve.

11.6.4 Requirements for installation of power supplies

11.6.4.1 Power supplies for pressure differential systems shall be separated from other circuits at the point of entry into the construction.

11.6.4.2 All equipment related to the power supply shall be installed with protection against mechanical damage unless they have inherent mechanical resistance.

11.6.4.3 Power supplies and related equipment shall be clearly labelled and identified as to their purpose and be secured against unauthorised operation, they shall be via access level 4 (see prEN 12101-10).

11.6.4.4 A power supply used for a pressure differential system shall be protected against exposure to fire for the time periods required by national provisions valid in the place of use of the system.

11.6.4.5 Secondary power supplies shall be totally separated from the primary power supply in order that damage to one supply does not affect the other.

11.6.4.6 The electrical distribution system shall be organised such that the power supply remains live when the remainder of the supplies in the construction works are isolated in an emergency.

11.6.4.7 Change over between the primary power supply and the secondary power supply shall be automatic.

11.7 Stand-by fans and drive mechanisms

11.7.1 General

If stand-by fans and drive mechanisms have to be applied to ensure that the system will operate in the event of an emergency, the installation shall consist of duplicate fans and/or motors depending on the type of system installed and the layout of building served.

11.7.2 Requirements for stand-by fans and drive mechanisms

11.7.2.1 The stand-by fans and motors shall be of the same type and duty as the primary pressure differential system equipment.

11.7.2.2 The change over from the primary pressure differential system equipment to the stand-by equipment shall be automatic.

11.7.2.3 Stand-by pressure differential system equipment shall be provided in accordance with the following criteria:

Where the pressure differential system equipment provides air under pressure to the only escape route within a building, a duplicate fan complete with its motor shall be provided. If a set of fans is used for this escape route, then only the fan with the highest capacity need be duplicated.

Where the pressure differential system equipment extracts air/smoke from the accommodation (depressurization) and is the sole means of creating the pressure differential within the only escape route from a building, a duplicate fan complete with its motor shall be provided. If a set of fans is used for this escape route, then only the fan with the highest capacity shall be duplicated.

Where there are two independent escape routes for each accommodation within a building (e.g. two staircases which may be entered from each floor), stand-by equipment for each route of escape need not be provided.

If there is just one protected escape route within a building but there is the possibility for people to enter another fire compartment with its own means of escape which cannot be affected in case of fire in the accommodation concerned, stand-by equipment need not be provided.

NOTE Where pressurization or depressurization is applied only for property protection it should be up to the building owners whether stand-by equipment is to be applied or not.

11.8 Distribution ductwork for pressure differential systems installation

11.8.1 General

For multi-storey buildings the preferred pressure differential system distribution system is a vertical duct running adjacent to the pressurized spaces.

When a common duct system serves several separate pressurized spaces it is important to ensure that, when the pressure in one or more spaces is disturbed because of open doors, the effect on the air supply to the others will be minimal. It is essential that the air supply used for pressurization is never in danger of contamination by smoke. Any increase or decrease in inlet or outlet pressure due to wind effect will be communicated through the building, possibly modifying the differential pressure balances through it. It is therefore essential that the air pressure conditions for the pressure differential system air intake and exhaust are made substantially independent of wind speed and direction.

When a pressure differential system is used in conjunction with an HVAC system in the building it is also essential that any effects of wind speed and direction are the same on both systems.

11.8.2 Requirements for distribution ductwork for pressure differential systems – installation

11.8.2.1 Ductwork shall be tested and classified in accordance with prEN 13501-3 or prEN 13501-4 and shall have a classification performance appropriate to the design criteria according to prEN 12101-7.

11.8.2.2 The ductwork sizing and layout shall be designed in accordance with national provisions valid in the place of use of the system, where applicable.

11.8.2.3 The ductwork construction shall be in accordance with the EN 1505 and EN 1506.

11.8.2.4 The air intake shall always be located away from any potential fire hazards. Air intakes shall be located on or near ground level (but well away from basement smoke vents) to avoid contamination by rising smoke. If this is not possible, air intakes shall be positioned at roof level.

11.8.2.5 When an air intake is distant from the fan, air shall be ducted from the intake to the fan.

11.8.2.6 Where an air intake is not at roof level, a smoke detector shall be provided in the intake duct or within the immediate vicinity of the supply ductwork in order to cause the automatic shut down of the pressure differential system if substantial quantities of smoke are present in the supply. An override switch shall be provided for fire brigade purposes in accordance with 11.4.2.5.

11.8.2.7 Where air intakes are positioned at roof level there shall be two air intakes, spaced apart and facing different directions in such a manner that they could not be directly downwind of the same source of smoke. Each inlet shall be independently capable of providing the full air requirements of the system. Each inlet shall be protected by an independently operated smoke control damper system in such a way that if one damper closes due to smoke contamination, the other inlet will supply the air requirements of the system without interruption. The discharge point of a smoke ventilation duct shall be a minimum of 1 m above the air intake and 5 m horizontally from it. An override switch to reopen the closed damper and to close the open damper shall be provided for fire brigade use.

11.8.2.8 Sheet metal ductwork shall be run within either the protected space, or in protected shafts. Brickwork ducts may be used provided that such ducts are used solely for air distribution and the internal surface is rendered to limit air leakage, a sheet metal lining is used, or it is shown that the leakage is satisfactory.

11.8.2.9 Fire dampers shall not be used in pressure differential system supply ductwork. If such ductwork penetrates a fire-resisting compartment, the ductwork shall be protected with suitable fire resisting material.

11.8.2.10 If different pressurized or depressurized zones are connected to the same fan or set of fans by a common system of ductwork and/or shafts, smoke control dampers shall be used.

11.8.2.11 Air supply grilles shall not be located near any major leakage path from a pressurized zone.

11.8.2.12 The pressure differential equipment, i.e. fan, motor and control gear, shall be housed either:

- a) in an enclosure with a fire resistance (of at least EI) of not less than one hour, preferably in a plant room separate from other plant, or
- b) at roof level if the fire resistance separation between the plant and the building below is not less than one hour within 5 m in any direction.

11.8.2.13 Access doors to the enclosure shall have a fire resistance (of at least EI) of no less than one hour and be self-closing. Where the pressure differential system protects a firefighting shaft, the level of fire resistance of access doors shall be the same as the firefighting shaft.

11.8.2.14 The fire resistance of ductwork used for transporting smoke and hot gases shall meet the requirements of prEN 12101-7.

EN 12101-6:2005 (E)

11.8.2.15 All smoke extraction pressurization release and depressurization ductwork and supporting construction shall have resistance to collapse and fire penetration equal to that of the structure within which it is installed.

11.8.2.16 The performance criteria of the ductwork shall identify conditions at ambient temperature.

11.8.2.17 Insulation of ducts shall be resistant to the transfer of excessive heat denoted by I (insulation) in the European classification of the resistance to fire performance.

12 Acceptance testing

12.1 General

The design recommendations made in this document presume that pressure differential systems are intended to overcome both stack effect pressures caused by unpressurized shafts elsewhere in the building and wind-induced pressure differences.

The following five acceptance tests: pressure differential, net pressure differential, air velocity, opening door force and activation of system shall be carried out only when the installation is complete and the pressure differential system, and where applicable air conditioning, have been commissioned and correctly balanced. All building work shall have been completed.

12.2 Acceptance test requirements

NOTE In buildings higher than eight stories, the tests specified in 12.2.1 and 12.2.2 should be carried out in groups of eight floors.

12.2.1 Pressure differential

The first acceptance test shall be carried out to establish pressure differential due to wind and stack effect with pressure differential fans switched off. The test(s) shall be carried out as follows:

- a) initiate the pressure differential system operation. Allow fans to operate for at least 10 min to establish steady air temperatures;
- b) switch off the pressure differential system fans, leaving all other components in their operational mode;
- c) measure the pressure differential between the pressurized space and the relevant accommodation;
- d) measure the pressure differential between the staircase that is to be pressurized and the relevant accommodation, on at least two storeys.

These readings shall be taken using a calibrated manometer, with the appropriate tube connections.

The pressure differential measured relative to the first acceptance test shall comply with the minimum values indicated in Figures 2, 3, 4, 5, 6 and 7.

12.2.2 Net pressure differential

12.2.2.1 Second acceptance test

Within 15 min after having completed the requirements of 12.2.1 the second acceptance test shall be to measure the net pressure differential across each door separating a pressurized and an unpressurized space to the relevant accommodation on all floor levels with the pressure differential system running.

12.2.2.2 The change in measurement between the first and second pressure readings shall be compared with the performance requirements specified for the design pressure differences.

12.2.3 Air velocity

12.2.3.1 The third acceptance test shall measure the air velocity through an open door separating a pressurized and an unpressurized space, and shall comply with the requirements in Clause 4 for the appropriate class of system. The test(s) shall be carried out as follows:

12.2.3.2 Measure the air velocity using a calibrated anemometer.

12.2.3.3 The measurement of flow velocity through the relevant doors shall be taken with all other doors open or closed in accordance with the appropriate class of system described in Clause 4. The doorway shall be clear of obstructions (see Figures 2, 3, 4, 5, 6 and 7 regarding the relevant door).

12.2.3.4 Take at least 8 measurements, uniformly distributed over the doorway, to establish an accurate air velocity. Calculate the mean of these measurements or alternatively move an appropriate measuring device steadily over the cross section of the open door and record the average air velocity.

12.2.3.5 The calibration of all test equipment shall be such that the measurements are accurate to $\pm 5\%$.

12.2.4 Opening door force

12.2.4.1 The fourth acceptance test shall be to measure the opening door force on the doors between the pressurized and unpressurized spaces as defined in Clause 4. The opening force at a particular door shall be measured as follows:

12.2.4.2 Actuate the pressure differential system.

12.2.4.3 Fasten the end of the force measuring device (e.g. a spring balance) to the door handle, on the side of the door in the direction of opening.

12.2.4.4 Release any latching mechanism, if necessary holding it open.

12.2.4.5 Pull on the free end of the force measuring device, noting the highest value of force measured as the door opens.

12.2.5 Activation of the system

The last test shall be to operate the automatic fire detection system (smoke detector) by injecting smoke into the detector head. This shall in turn operate the central fire alarm panel, thus activating the pressure differential system.

13 Maintenance

13.1 General

The pressure differential system, including the smoke detection system or any other type of fire alarm system used, the switching mechanism, the fans, the equipment power supply arrangements and the automatically operated ventilation equipment, shall be subject to a regular maintenance and functional testing procedure.

The person responsible for the design of the system shall provide the occupier with a maintenance check list. Records shall be kept of all maintenance and functional testing by the building management.

Any records shall indicate repeated faults, where a potential design fault in the system can be easily highlighted.

13.2 Maintenance requirements

- 13.2.1 The equipment shall be included in the Building Services maintenance schedule.
- 13.2.2 A maintenance and functional test schedule shall be prepared.
- 13.2.3 All unsatisfactory findings or defects found regarding the maintenance of equipment shall be recorded in the log book and reported to the building management.
- 13.2.4 Maintenance of equipment shall be in accordance with the manufacturer's instructions.
- 13.2.5 Records shall indicate all reports regarding repeated faults that can be deemed to be design faults.

13.3 Weekly tests

- 13.3.1 Each week the pressure differential system shall be actuated. While the system is operating, checks shall be made that the fans are running satisfactorily and that the ventilation system has operated.
- 13.3.2 Each week the fuel level for the secondary power supply shall be checked so that there is sufficient fuel to run the generator for the required time, if the secondary power supply is a generator.

13.4 Monthly tests

Each month, in addition to the weekly tests, the emergency power supply and stand-by equipment shall be tested as follows:

13.4.1 A failure of the primary power supply shall be simulated and a check made that the system has switched automatically to the secondary power supply. If the secondary power supply is provided by a diesel generator it shall energise the system for a minimum of 1 h.

13.4.2 A zero airflow condition shall be simulated and a check made that the stand-by fans are running if they are provided.

13.5 Yearly tests

Every 12 months, in addition to the manufacturer's recommendation and monthly tests, the entire pressure differential system shall be tested by following the acceptance test procedure detailed in 12.2.1, 12.2.2, 12.2.3 and 12.2.4.

13.6 Re-tests

The entire pressure differential system shall be re-tested in accordance with 12.1 (acceptance testing) following any modification to the building that could affect the pressure differential system, e.g. alterations to internal partitions, extensions and alterations to the pressure differential system.

13.7 Test results

The results of the tests shall be recorded as stated in Clause 14.

13.8 Access facility for maintenance

The system designer shall provide easy access for maintenance purposes. The system needs to be designed with consideration to installation, measurement/testing, adjustments, maintenance repair and replacement in accordance with the following:

- a) access shall be provided to enable satisfactory installation, repair and replacement to be carried out;

- b) access shall be provided for adjustment of the inlet guide vanes of the fan(s) and the distribution system balancing dampers;
- c) access doors shall be provided in ductwork adjacent to balancing dampers and fire dampers;
- d) sufficient clearance around generators shall be provided;
- e) Access panels shall be placed so as to give safe access where relevant to damper manual release mechanisms.

NOTE It is recommended that visual indication or electrical indication, identifying the exact position of dampers, should be incorporated within the system.

14 Documentation

14.1 Approving authority requirements

The approving authority shall be provided with full details of the installation. These shall include:

- a) full calculations showing the design criteria (see Clause 15);
- b) full specification details of the equipment used (see Clause 11);
- c) complete plans showing position and protection of the fan and associated electrical control equipment, and the location of fresh air inlets (see Clause 11);
- d) constructional details of the ductwork and duct terminals used for the pressure differential system (Clauses 5 and 11);
- e) any other relevant constructional information required by the approving authority (see Clause 11);
- f) full operational details describing in words and by diagram the exact sequence of actions that will occur in the pressure differential system and in the normal ventilating system when a fire occurs in the building (see Clauses 4 and 7);
- g) a complete maintenance schedule indicating the maintenance checks needed for each item of the equipment and the frequency of these checks (see Clause 12);
- h) on completion, the results of the tests carried out on the pressure differential system (see Clause 13).

14.2 Occupier/owner requirements

The occupier/owner of the building shall be provided with a clear description of the purpose and operation of the installation. This shall include:

- a) a clear description of the purpose of the installation (see Introduction);
- b) a concise statement in words assisted by diagrams of the operation of the installation giving a clear indication of the sequence of events that will follow an alarm of fire (see Clause 4);
- c) a complete maintenance schedule indicating the maintenance checks needed for each item of the equipment and the frequency of these checks (see Clause 13);
- d) a check list in the maintenance schedule of the actions necessary for maintenance, together with a register that will form a record of the maintenance carried out and in which any faults found, and any corrective actions taken, may be recorded (see Clause 13);

EN 12101-6:2005 (E)

- e) a set of 'as installed' drawings for retention on the site (see Clause 13);
- f) a statement to indicate that alterations to:
 - accommodation areas (e.g. sub-dividing floor areas);
 - floor covering under doorsmay affect the operation of the pressure differential system (see Clause 13).

15 Design calculations

15.1 General

The design of a smoke control system using pressure differentials involves balancing the airflows into and out of the building and analysing the pressure differentials across smoke barriers. It is important that all the relevant airflow paths shall be identified and their effective flow areas evaluated. The typical leakage paths that may exist in a building are open doors, gaps around closed doors, lift doors, windows etc. Attention shall also be given to the inherent leakage due to construction cracks, etc. that will exist in walls, floors and partitions. Both the type of construction material and the quality of workmanship will significantly affect the leakage area.

When analysing the air needed to create a pressure differential between the protected and unprotected spaces within a construction the procedure will vary dependent upon:

- a) the shape of the construction;
- b) whether the kit is pressurizing the protected space or depressurizing the unprotected space.

15.2 Design calculation requirements

The following steps listed below will provide a logical method of evaluating the air needed.

NOTE Calculation methods that can be used are contained in Annex A. The corresponding calculation method is shown in brackets after the requirement.

15.2.1 Identify all the airflow paths with doors closed. The paths through which air escapes or is released will include all:

- a) cracks around doors between the protected space and the unprotected space;
- b) cracks through the fabric of the building between the protected and unprotected spaces in the construction;
- c) the openings provided for the release of air from the unprotected spaces, or the openings provided for makeup air from the protected spaces;
- d) cracks through the fabric of the building between the unprotected spaces in the construction.

15.2.2 Evaluate the effective leakage paths between each adjacent space (see A.1).

15.2.3 Calculate the total equivalent leakage area via gaps around doors Q_D (see A.2).

15.2.4 Calculate the leakage rate via cracks around all the windows Q_{Window} (see A.2).

15.2.5 Calculate the leakage rate via lift landing doors $Q_{L,d}$ (see A.2).

15.2.6 Calculate the leakage via other areas containing mechanical extraction systems Q_{Tm} (see A.2).

15.2.7 Calculate the leakage via other air paths Q_{Other} (see A.2).

NOTE Where a depressurization system is being designed, Q_{Other} will include any losses through the external face of the construction.

15.2.8 Calculate the total air supply required with all the doors closed Q_{DC} (see A.3).

15.2.9 Identify which doors are open, referring to the classes of system (see 4.1 to 4.7 inclusive, and Figures 2, 3, 4, 5, 6 and 7).

15.2.10 Identify all the airflow paths regarding doors open and evaluate (see A.1).

15.2.11 Calculate the total air supply required with all the doors noted as open in 15.2.9, Q_{DO} (see A.3).

15.2.12 Calculate the total supply air required with all the appropriate doors open plus an allowance of 15 % for ductwork losses, Q_{SDO} .

15.2.13 Calculate the total supply air required plus a factor of 50 % for unknown leakages not discussed in the previous normative statements Q_S .

15.2.14 Use the larger value of the calculated Q_S or Q_{SDO} above for the fan duty.

15.2.15 For pressurization systems use the larger value of the calculated Q_S or Q_{SDO} above to calculate the air release requirements from unpressurized spaces with open doors (see A.4).

For depressurization systems use the larger value of the calculated Q_S or Q_{SDO} above to calculate the 'makeup' air needed to be admitted into the space which is not depressurized.

15.2.16 Either calculate the appropriate air release vent area from the pressurized space (over pressure relief) (see A.5) or calculate the appropriate air makeup vent area from the depressurized space (over depression relief) (see A.5).

15.2.17 Calculate the door opening forces (see A.6).

15.2.18 The actual fan duty can then be calculated after taking in account the door open and door closed calculation from 15.2.1 to 15.2.17.

16 Evaluation of conformity

16.1 General

The compliance of a pressure differential system kit with the requirements of this standard shall be demonstrated by:

- initial type testing or evaluation;
- factory production control.

NOTE The manufacturer is a natural or legal person, who places the kit on the market under his own name. Normally, the manufacturer designs and manufactures the kit himself. As a first alternative, he may have it designed, manufactured, assembled, packed, processed or labelled by subcontracting. As a second alternative he may assemble, pack, process, or label ready-made kits.

The manufacturer shall ensure:

EN 12101-6:2005 (E)

- that the initial type testing or evaluation in accordance with this document is initiated and carried out (where relevant, under the control of a product certification body), and
- that the kit continuously complies with the initial type testing samples, for which compliance with this document has been verified.

The manufacturer shall always retain the overall control and shall have the necessary competence to take responsibility for the kit.

The manufacturer, when affixing the CE marking to the kit, is fully responsible for the conformity of that kit to all relevant regulatory requirements. However, where the manufacturer uses components already shown to conform to those requirements relevant for that component (e.g. by CE marking) the manufacturer is not required to repeat the evaluation which lead to such conformity. Where the manufacturer uses components not shown to conform, it is his responsibility to undertake the necessary evaluation to show conformity.

16.2 Initial type testing or evaluation

16.2.1 General

Initial type testing or evaluation shall be performed to demonstrate conformity with this document.

NOTE 1 Hereafter 'type testing' refers to all means of evaluation: testing, calculation or assessment of the detailed engineering plan.

As the objective of the general testing procedures is to establish the ability of the pressure differential system kit to achieve the kit design and performance requirements and classification in its operational position, and to continue to act as a barrier to smoke and heat for a designated period of time, the complete kit (i.e. including motors and fixings) to be installed shall be tested.

The kit supplier shall submit a sufficient number of system designs/kits for the purposes of initial type evaluation to ensure that there is adequate proof of his capability to work in accordance with the requirements of this document. See also 16.3.

NOTE 2 It may not always be necessary for all kits to be submitted for evaluation.

16.2.2 Modifications

In the case of modification of the kit or of the method of production (where these may affect the stated properties), initial type testing shall be performed. All characteristics given in this document, which may be changed by the modification, shall be subject to this initial type testing, except as described in 16.2.3.

16.2.3 Previous tests and kit families

Tests previously performed in accordance with the provisions of this document may be taken into account providing that they were made to the same or a more rigorous test method under the same system of attestation of conformity on the same kit or kits of similar design, construction and functionality, such that the results are applicable to the kit in question.

Kits may be grouped into families where one or more characteristics are the same for all kits within that family or the test results are representative of all kits within that family. In this case not all kits of the family have to be tested for the purposes of the initial type testing.

16.2.4 Test samples

Test samples shall be representative of the normal production. If the test samples are prototypes, they shall be representative of the intended future production and shall be selected by the manufacturer.

If the technical documentation of the test samples does not give a sufficient basis for later compliance checks, a reference sample (identified and marked) shall remain available for this purpose.

16.2.5 Test report

Any initial type testing and its results shall be documented in a test report.

16.3 Factory product control (FPC)

16.3.1 General

The manufacturer shall establish, document and maintain an FPC system to ensure that the kits placed on the market conform with the stated performance characteristics. FPC is the permanent internal control of production exercised by the manufacturer.

If the manufacturer has the kit designed, manufactured, assembled, packed, processed and labelled by subcontracting, FPC of the original manufacturer may be taken into account. However, where subcontracting takes place, the manufacturer shall retain the overall control of the kits and ensure that he receives all the information that is necessary to fulfil his responsibilities according to this document. The manufacturer who subcontracts all of his activities may in no circumstances pass his responsibilities on to a subcontractor.

All the elements, requirements and provisions adopted by the manufacturer shall be documented in a systematic manner in the form of written policies and procedures. This production control system documentation shall ensure a common understanding of conformity evaluation and enable the achievement of the required component characteristics and the effective operation of the production control system to be checked.

The FPC system shall ensure that the compliance of the system design and the preparation of system documentation with the requirements of this document is maintained. The FPC system shall also cover the selection of the components and processing (assembling, packing and labelling) of the kit.

Factory production control therefore brings together operational techniques and all measures allowing maintenance and control of the conformity of the kit with its technical specifications. Its implementation may be achieved by controls and tests on measuring equipment, raw materials and constituents, processes, machines and manufacturing equipment and finished kits, including material properties in products, and by making use of the results thus obtained.

16.3.2 General requirements

The FPC system may be part of a Quality Management system, e.g. in accordance with EN ISO 9001:2000.

16.3.3 Product specific requirements

16.3.3.1 The FPC system shall:

- address this document, and
- ensure that the kits placed on the market conform with the stated performance characteristics.

16.3.3.2 The FPC system shall include a product specific FPC- or Quality-plan, which identifies procedures to demonstrate conformity of the kit at appropriate stages, i.e.:

- a) the controls and tests to be carried out prior to and/or during manufacture, including checks on the system design and documentation, according to a frequency laid down, and/or
- b) the verifications and tests to be carried out on finished kits according to a frequency laid down.

EN 12101-6:2005 (E)

If the manufacturer uses finished kits, the operations under b) shall lead to an equivalent level of conformity of the kit as if normal FPC had been carried out during the production.

If the manufacturer carries out parts of the production himself, the operations under b) may be reduced and partly replaced by operations under a). Generally, the more parts of the production that are carried out by the manufacturer, the more operations under b) may be replaced by operations under a). In any case the operation shall lead to an equivalent level of conformity of the kit as if normal FPC had been carried out during the production.

NOTE Depending on the specific case, it may be necessary to carry out the operations referred to under a) and b), only the operations under a) or only those under b).

The operations under a) centre as much on the intermediate states of the kit as on manufacturing machines and their adjustment, and test equipment etc. These controls and tests and their frequency are chosen based on kit type and composition, the manufacturing process and its complexity, the sensitivity of kit features to variations in manufacturing parameters etc.

The manufacturer shall establish and maintain records which provide evidence that the production has been sampled and tested. These records shall show clearly whether the production has satisfied the defined acceptance criteria. Where the kit fails to satisfy the acceptance measures, the provisions for non-conforming products shall apply, the necessary corrective action shall immediately be taken and the kits or batches not conforming shall be isolated and properly identified. Once the fault has been corrected, the test or verification in question shall be repeated.

The results of controls and tests shall be properly recorded. The kit description, date of manufacture, test method adopted, test results and acceptance criteria shall be entered in the records under the signature of the person responsible for the control/test. With regard to any control result not meeting the requirements of this document, the corrective measures taken to rectify the situation (e.g. a further test carried out, modification of manufacturing process, throwing away or putting right of the kit) shall be indicated in the records.

16.3.3.3 Individual kits or batches of kits and the related manufacturing details shall be completely identifiable and retraceable.

16.3.4 Initial inspection of factory and FPC

16.3.4.1 Initial inspection of factory and FPC shall generally be carried out when the production is already running and the FPC is already in practice.

It is, however, possible that the initial inspection of factory and FPC is carried out before the production is already running and/or before the FPC is already in practice.

16.3.4.2 The following shall be assessed:

- the FPC-documentation, and
- the factory.

In the assessment of the factory it shall be verified:

- a) that all resources necessary for the achievement of the kit characteristics required by this document are or will be (see 16.3.4.1) available, and
- b) that the FPC-procedures in accordance with the FPC-documentation are or will be (see 16.3.4.1) implemented and followed in practice, and
- c) that the kit complies or will comply (see 16.3.4.1) with the initial type testing samples, for which compliance with this document has been verified, and

d) whether the FPC system is part of a Quality Management system in accordance with EN ISO 9001:2000 (see 16.3.2) and as part of this Quality Management system is certified and has yearly surveillance by a certification body, who is recognised by an accreditation body which is member of the "European Co-operation for Accreditation" and which has signed the "Multilateral agreement" (MLA) there.

16.3.4.3 All factories of the manufacturer where, for the relevant kit, final assembling and/or final testing is performed, shall be visited to verify that the conditions of 16.3.4.2 a) to c) are in place. One visit may cover one or more kits, production lines and/or production processes.

16.3.4.4 Assessments previously performed in accordance with the provisions of this document may be taken into account providing that they were made to the same system of attestation of conformity on the same kit or kits of similar design, construction and functionality, such that the results may be considered applicable to the kit in question.

16.3.4.5 Any assessment and its results shall be documented in a report.

16.3.5 Continuous surveillance of FPC

16.3.5.1 All factories which have been assessed according to 16.3.4 shall be re-assessed at least once a year, except as stated in 16.3.5.2. In this case each FPC visit shall verify a different kit or production process.

16.3.5.2 In the case of third party certification, if the manufacturer provides proof of continuing satisfactory operation of his FPC system the frequency of the re-assessment may be reduced to once every four years.

NOTE 1 Sufficient proof can be the report of a certification body, see 16.3.4.2 d).

NOTE 2 If the overall Quality Management system in accordance with EN ISO 9001:2000 is well implemented (verified in the initial assessment of factory and FPC) and continuously practised (verified in QM-audits), it can be assumed that the integrated FPC-relevant part is well covered. On this basis, the work of the manufacturer is well surveyed, so that the frequency of special FPC-surveillance assessments can be reduced.

16.3.5.3 Any assessment and its results shall be documented in a report.

16.3.6 Procedure for modifications

In the case of modification of the kit, the method of production or the FPC system (where these may affect the stated properties), a re-assessment of the factory and of the FPC system shall be performed for those aspects which may be affected by the modification.

Any assessment and its results shall be documented in a report.

Annex A (informative)

Design recommendations

A.1 Effective flow areas

A.1.1 General

An example of a parallel path occurs when all the doors opening out of a stair lead directly to an unpressurized space (Figure A.1).

Leakage paths in series occur when there is an intermediate space into which the air from a pressurized space first flows before finally leaking out to the unpressurized space through other leakage paths. An example of this is the simple lobby interposed between the stair and the accommodation (Figure A.2).

NOTE These calculations apply only to leakage paths having the same value of R (see A.3.1.1 Note 1). Furthermore in the case of equation (A.4) the value of R should be 2. However, since the predominant leakage paths will almost invariably be through doors, the contribution from window leakage is likely to be small and this calculation may be used as an appropriate estimate when windows form part of the leakage path.

A.1.2 Parallel leakage paths

The effective leakage area is the sum of the leakage areas concerned:

$$A_e = A_1 + A_2 + A_3 + A_4 + \dots + A_N \quad (A.1)$$

The effective leakage area of the four parallel paths in Figure A.1 will be:

$$A_e = A_1 + A_2 + A_3 + A_4 \quad (A.2)$$

A.1.3 Series leakage paths

The effective leakage area of series paths is:

$$A_e = \left(\frac{1}{A_1^2} + \frac{1}{A_2^2} + \frac{1}{A_3^2} + \dots + \frac{1}{A_N^2} \right)^{-\frac{1}{2}} \quad (A.3)$$

The effective leakage area of the four series paths in Figure A.2 is:

$$A_e = \left(\frac{1}{A_1^2} + \frac{1}{A_2^2} + \frac{1}{A_3^2} + \frac{1}{A_4^2} \right)^{-\frac{1}{2}} \quad (A.3a)$$

In the context of pressurization analysis there are frequently only two paths in series, in which case:

$$A_e = \frac{A_1 \times A_2}{(A_1^2 + A_2^2)^{\frac{1}{2}}} \quad (A.4)$$

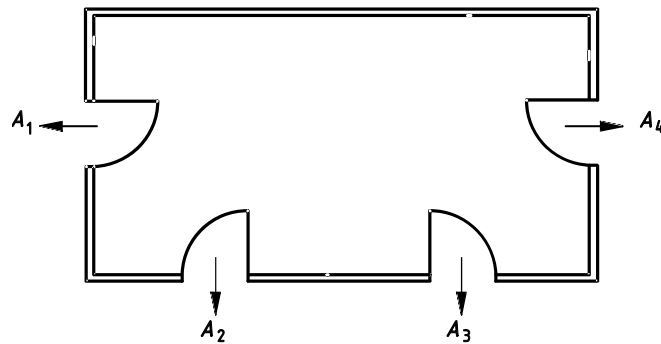
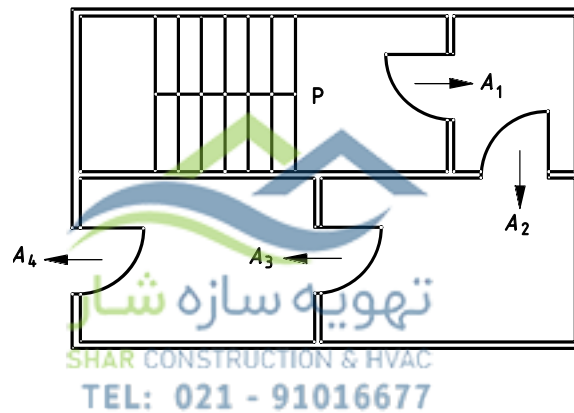

Figure A.1 — Leakage paths in parallel



Key
P Pressurized space

Figure A.2 — Leakage paths in series

A.1.4 Combinations of series and parallel leakage paths

The total effective leakage of combinations of series and parallel paths can usually be obtained by successively combining simple groups of individual leakages into their equivalent single path (see Figure A.3 for example). Such calculations apply strictly only to leakage paths for which the value of R in equation (A.16) is 2 (i.e. for doors). However, they may be used for an approximate calculation when windows form part of a series leakage path.

$$A_{4/5} = A_4 + A_5 \tag{A.5}$$

$$A_{9/10} = A_9 + A_{10} \tag{A.6}$$

Thus in Figure A.3:

$$A_{1/2} = \frac{A_1 \times A_2}{(A_1^2 + A_2^2)^{\frac{1}{2}}} \tag{A.7}$$

EN 12101-6:2005 (E)

and in Figure A.3:

$$A_{3/5} = \frac{A_3 \times A_{4/5}}{\left(A_3^2 + A_{4/5}^2\right)^{\frac{1}{2}}} \quad (\text{A.8})$$

and similarly for $A_{6/7}$ and $A_{8/10}$.

In Figure A.3:

$$A_{3/10} = A_{3/5} + A_{6/7} + A_{8/10} \quad (\text{A.9})$$

The total equivalent leakage from the pressurized space is given by:

$$A_{1/10} = \frac{A_{1/2} \times A_{3/10}}{\left(A_{1/2}^2 + A_{3/10}^2\right)^{\frac{1}{2}}} \quad (\text{A.10})$$

as shown in Figure A.3.



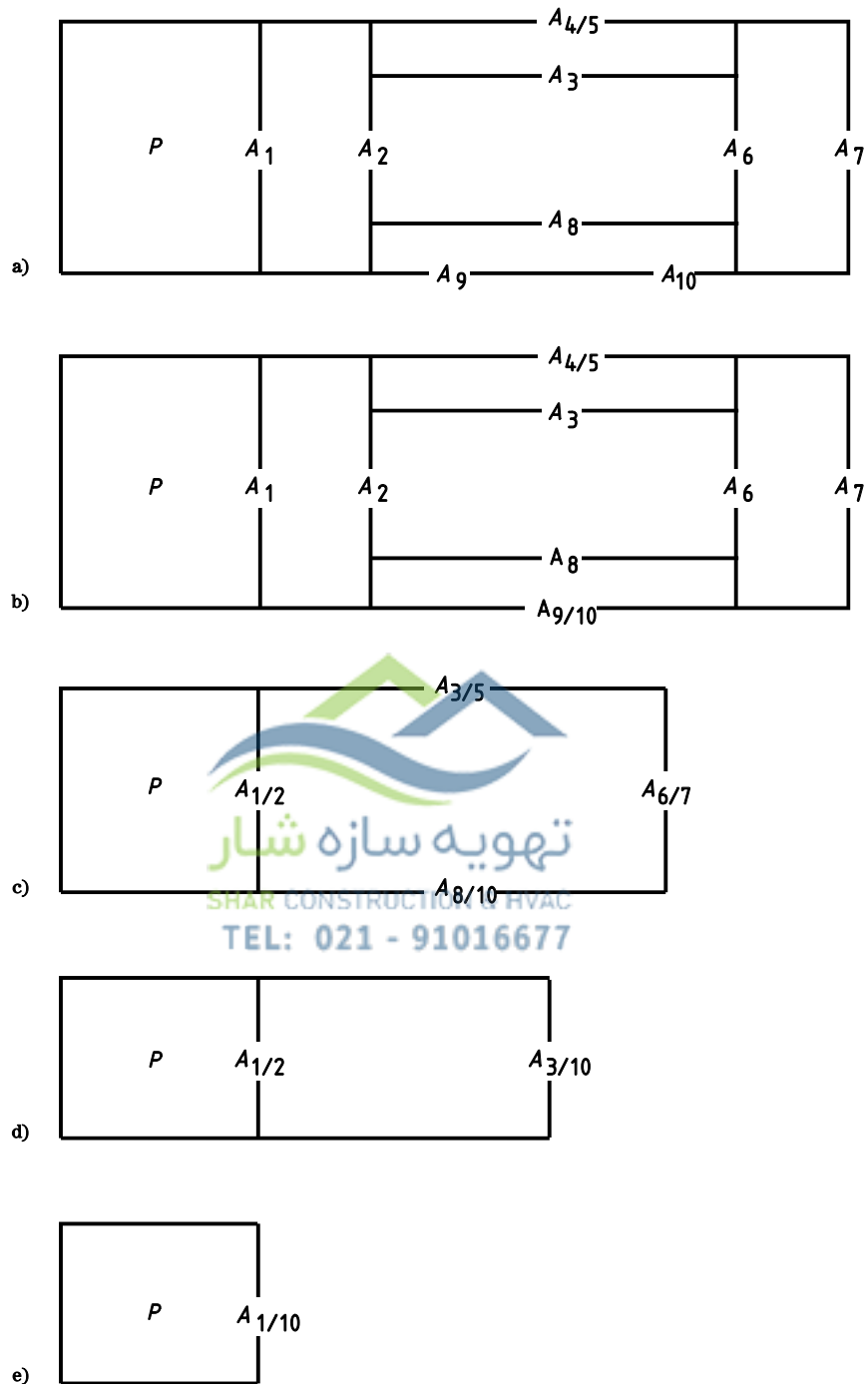

Key
 1 Pressurized space

Figure A.3 — Combination of series and parallel leakage paths

A.2 Estimation of leakage

A.2.1 Estimation of leakage via windows

The total air leakage via cracks around windows should be estimated using the following equation:

$$Q_{Window} = 0,83 \times A_W \times P^{1/R} \quad (A.11)$$

The total effective leakage area for all the windows should be estimated using the method outlined A.1.

Typical leakage areas for the types of windows likely to be found in the pressurized space are given in Table A.4.

Table A.1 — Values of *K*

A_x/A_G	<i>K</i>
4 or more	1
2	0,9
1	0,7
0,5	0,45
0,25 or less	0,25

NOTE The value of A_G including airflow grilles and/or large gaps for air transfer should also to be used to calculate the value of Q_n when the leakage area is greater than the normal total area of cracks.

A.2.2 Estimation of leakage via lift landing doors

If the lift well is independently pressurized, then it may be assumed that leakage via this route is negligible.

If the lift well is not pressurized but is connected to a pressurized lobby or other space then the overall flow will depend upon the following leakage paths:

- between the lobbies and the lift well on all storeys, and
- between the lift well and the external air.

The following equation may be used to estimate the total air leakage in these circumstances:

$$Q_{Ld} = 0,83 \times \left(\frac{1}{A_t^2} + \frac{1}{A_f^2} \right)^{-\frac{1}{2}} \times P_L^{\frac{1}{2}} \quad (A.12)$$

Generally:

$$A_t = N_L \times A_d \quad (A.13)$$

The above calculation relates to one lift and it is assumed that the lift well is protected. A separate calculation should be made for each lift.

Where there are two or more lifts in a common well, it is sufficient for the purpose of calculation to treat each lift as being in its own single well, in which case the value of A_F used should be that relating to each separate lift (usually A_F for the large common well divided by the number of lifts in that well).

A.2.3 Estimation of leakage via other areas containing mechanical extraction systems

When toilets or other areas that are directly connected to the pressurized space have mechanical extract systems, the leakage rate into them may be estimated as follows:

- when the extract fan is running, taken to be the extract rate in cubic metres per second, or
- when the extract fan is off, calculated from:

$$Q_{Tn} = Q_n \times K \quad (\text{A.14})$$

A.2.4 Estimation of leakage via other paths

Other combinations of series and parallel leakage paths may occur in other situations and the above methods (suitably adapted to take account of the particular circumstances) may be used.

A.2.5 Estimation of leakage via closed doors

The total air leakage rate past closed doors should be calculated using the following equation:

$$Q_D = 0,83 \times A_e \times P^{1/R} \quad (\text{A.15})$$

The total effective leakage area for all the doors should be estimated using the method outlined in A.1.

Typical leakage areas for the types of door likely to be found as the closure to a pressurized space are shown in Table A.4.



A.3 Air flow

A.3.1 General

The air supply required for a pressure differential system is determined by the air leakage areas. The air supply requirements should be considered for two situations: all doors closed and all doors open.

A.3.2 Calculation of air flow

When air flows through an opening, the flow can be expressed in terms of the area of the restriction and the pressure differential across the opening by the following equation:

$$Q = 0,83 \times A_e \times P^{1/R} \quad (\text{A.16})$$

NOTE For wide cracks such as those around doors and large openings, the value of R may be taken to be 2 but for narrow leakage paths formed by cracks around windows a more appropriate value of R is 1,6.

The flow velocities and pressure differentials given in Table A.2 have been derived from equation (A.16) assuming $R = 2$ and A_e is 1 m^2 , and may be used as a means of quickly determining leakage rates and pressure differentials around door gaps and through large openings.

Table A.2 — Airflow velocities through gaps and large openings

Pressure differential, Pa	Airflow velocity, m/s
50	5,9
25	4,2
8,5	2,4
6	2,0
4	1,7

The rate of air leakage is primarily a function of the effective area of the leakage path and the pressure differential across it.

In calculating the air supply two major assumptions should be made. These are:

- a) that the leakage paths identified and the areas used in the calculations will apply to the building when it is completed;
- b) that there are no unidentified leakage paths out of the pressurized space.

The air supply required is determined by summing the individual leakage rates via the routes listed in a) to e) and making an allowance for uncertainties in the values of the leakage areas that have been assumed. Based upon experience it is recommended that the total air supply rate should be determined by adding at least 50 % to the calculated leakage rate, i.e.

$$Q_S = 1,5 \times Q_{DC} \quad (A.17)$$

Q_{DC} is estimated using the following, utilising the appropriate leakage areas for the case being considered:

$$Q_{DC} = Q_D + Q_{Window} + Q_{Ld} + Q_{Tm} + Q_{Other} \quad (A.18)$$

A.3.3 Estimation of leakage with the doors open to the fire floor

The total air leakage rate with the doors open to the fire floor should be estimated using the following procedure.

A_{VA} should be estimated using the procedure outlined in A.4.

$$P_{US} = \left(\frac{Q_{DO}}{0,83 \times A_{VA}} \right)^2 \quad (A.19)$$

Having calculated the required pressure within the unpressurized space, the pressure within the lobby should be calculated using:

$$P_{LOB} = P_{US} + \left(\frac{Q_{DO}}{0,83 \times A_{door}} \right)^2 \quad (A.20)$$

The effective leakage area other than through the fire door should now be calculated utilising the procedures within this document. This being accomplished, the total air supply required with the doors open to the fire floor should now be calculated as a first order correction:

$$Q_{LOB} = 0,83 \times \left\{ A_{rem} + \left(\frac{1}{A_{VA}^2} + \frac{1}{A_{door}^2} \right)^{-\frac{1}{2}} \right\} \times P_{LOB}^{\frac{1}{2}} \quad (A.21)$$

The total air required taking into account ductwork losses should now be calculated.

$$Q_{SDO} = 1,15 \times Q_{lob} \quad (A.22)$$

A.4 Air release requirements from unpressurized spaces with open doors

A.4.1 General

The sizing of air release equipment is based on the net volume of pressurizing air flowing into the fire storey, (excluding the air leakage to atmosphere via lift shafts and toilets). The appropriate airflow value for the open door condition in Clause 4 should be taken for this purpose. In the following calculations this value is referred to as Q_{DO} .

A.4.2 Estimation of vent area requirements

Where special vents are necessary, the total effective area per storey should be estimated as follows:

$$Q_{DO} / A_{VA} = 2,5 \quad (A.23)$$

where Q_{DO} is based on the required velocity at the door(s) to the fire compartment.

A.4.3 Estimation of size of vertical air release shafts

Unless detailed pressure loss calculations are carried out, the minimum sizes of shaft and vents that are acceptable for this purpose should be:

$$A_{vs} = Q_{DO} / 2 \quad (A.24)$$

A.4.4 Estimation of mechanical extract requirements

The extract rate per floor when a free path exists through open doors to the pressurized space should be not less than $Q_{DO} \text{ m}^3/\text{s}$.

The above air release specifications are based upon an assumed pressure differential between the accommodation and the outside air of 10 Pa. It is possible, however, to increase the airflow rate or reduce the required vent area if the pressure differential between the accommodation and outside is increased. In such circumstances it is necessary to evaluate the air leakage rate in accordance with equation (A.16).

Where two or more pressurized stairs or lobbies open into the same unpressurized space then the area of the relief vent per storey should reflect the total air passing on to the floor from the pressurized spaces.

Where the unpressurized space is partitioned into offices or similar units then the relief vents should be provided between the door into the pressurized space and the start of the partitioning.

A.5 Estimation of area of relief vent required in the pressurized space

A.5.1 General

Where the air supply needed to provide the required airflow through the open door into the fire room is greater than the air supply to the stair or lobby needed to satisfy the pressure differential requirement, then an excess pressure will be developed in the stair (or lobby) when the fire door is closed.

In this case a pressure operated relief vent, area A_{PV} , should be provided out of the pressurized space, to ensure that the specified door opening force of 100 N is not exceeded.

$$\text{Then: } A_{PV} = \frac{Q_{fr} - Q_p}{0,83 \times 60^{\frac{1}{2}}} \quad (\text{A.25})$$

A.6 Calculation of door opening forces

A.6.1 General

The maximum pressure differential across a door opening into a pressurized space should be determined as a function of the door configuration, using the following equation:

$$P = \frac{2(100 - F_{dc})(W_d - d)}{D_A \times W_d} \quad (\text{A.26})$$

If, at the design stage, the force required to overcome the door closer is unknown, a maximum pressure differential of 60 Pa may be utilised for design purposes.

A.6.2 Air leakage data

The leakage areas given in Tables A.3 to A.6 are provided for guidance only. Leakage areas are highly dependent on the quality of workmanship and actual values may vary from the range given.

Table A.3 — Air leakage data from doors

Type of door	Leakage area m ²	Pressure differential Pa	Air leakage m ³ /s
Single-leaf opening into a pressurized space	0,01	8	0,02
		15	0,03
		20	0,04
		25	0,04
		50	0,06
Single-leaf opening outwards from a pressurized space	0,02	8	0,05
		15	0,06
		20	0,07
		25	0,08
		50	0,12
Double-leaf	0,03	8	0,07
		15	0,10
		20	0,11
		25	0,12
		50	0,18
Lift landing door	0,06	8	0,14
		15	0,19
		20	0,22
		25	0,25
		50	0,35

Table A.4 — Air leakage data from windows

Type of window	Crack area m ² per m length	Pressure differential Pa	Air leakage m ³ /s
Pivoted, no weather stripping	2,5 x 10 ⁻⁴	8	0,77 x 10 ⁻³
		15	1,1 x 10 ⁻³
		20	1,4 x 10 ⁻³
		25	1,6 x 10 ⁻³
		50	2,4 x 10 ⁻³
Pivoted, and weather stripped	3,6 x 10 ⁻⁵	8	0,11 x 10 ⁻³
		15	0,16 x 10 ⁻³
		20	0,19 x 10 ⁻³
		25	0,22 x 10 ⁻³
		50	0,34 x 10 ⁻³
Sliding	1,0 x 10 ⁻⁴	8	0,30 x 10 ⁻³
		15	0,45 x 10 ⁻³
		20	0,54 x 10 ⁻³
		25	0,62 x 10 ⁻³
		50	0,95 x 10 ⁻³

Table A.5 — Air leakage data for walls

Construction element	Wall tightness	Leakage area ratio A_{LW}/A_{Wall}
Exterior building walls (including construction cracks, cracks around windows and doors)	Tight	$0,7 \times 10^{-4}$
	Average	$0,21 \times 10^{-3}$
	Loose	$0,42 \times 10^{-3}$
	Very loose	$0,13 \times 10^{-2}$
Internal and stair walls (including construction cracks, but not cracks around windows and doors)	Tight	$0,14 \times 10^{-4}$
	Average	$0,11 \times 10^{-3}$
	Loose	$0,35 \times 10^{-3}$
Lift well walls (including construction cracks, but not cracks around windows and doors)	Tight	$0,18 \times 10^{-3}$
	Average	$0,84 \times 10^{-3}$
	Loose	$0,18 \times 10^{-2}$

Table A.6 — Air leakage data for floors

Construction element	Wall tightness	Leakage area ratio A_{LF}/A_{Floor}
Floors (includes construction cracks and cracks around penetrations)	Average	$0,52 \times 10^{-4}$

Annex B (informative)

Solutions for inability to obtain design pressure differential

The following guidance relates specifically to pressurization systems. However, similar principles, suitably adapted, may also be applied to depressurization systems.

B.1 The pressure differentials recommended in this document are intended to take account of fire buoyancy and external wind conditions. If tests are carried out where external conditions give rise to high wind and gusts, it may not be possible to achieve the design pressure differential.

B.2 Where stack effect is likely to be a significant factor, this may be minimized by operating the pressure differential system for a period of one hour before testing so that the external air and shaft temperatures can equalize.

B.3 Apart from external conditions, there are three main reasons for failing to achieve the desired pressure differentials:

- a) Insufficient air supply to the pressurized space. The required pressure differential will not be established if there is insufficient air supply to the pressurized space. There are two methods of assessing the airflow to the pressurized zones:
 - i) the first method is to measure the total air supply at the fan, subtract the ductwork leakage and then proportion the remaining airflow to each terminal according to measurements taken during commissioning;
 - ii) the second method is to measure the airflow out of each terminal.

If the measured airflow is below the design value, then selected doors separating the pressurized and unpressurized spaces should be opened and the airflow measured again. If the airflow increases with the doors open, a ductwork leakage test should be performed and remedial action taken.

- b) Excess leakage from pressurized space. It is important that the architect and builder are aware of the need for the construction to be as airtight as possible.

Where the measured pressure differential is lower than the design value, it is often because the structure exceeds the level of leakage allowed for in the design. The sealing of all penetrations through the pressurized space should be checked, e.g. trunking, pipework, ductwork and light fittings, and improved where necessary. A check should also be made of the fit of doors and the gap sizes under them, and of the installation of false ceilings, etc.

If the leakage does not exceed the anticipated level, then it will be necessary to increase the air supply rate and possibly also to increase the leakage from the unpressurized spaces.

- c) Insufficient leakage from unpressurized spaces. If during the procedures outlined in item (a) the air supply to the pressurized spaces increases when doors are opened between the pressurized and unpressurized spaces, the likely cause is a lower than expected rate of leakage from the unpressurized space. That the ventilation system has operated as required on all storeys should be ensured. If this is functioning normally, then it may be necessary to add further vents to increase the escape of air.

Annex ZA (informative)

Clauses of this European Standard addressing essential requirements or other provisions of the Construction Products Directive

ZA.1 Scope and relevant characteristics

This European Standard has been prepared under a mandate given to CEN by the European Commission and the European Free Trade Association.

The clauses of this European Standard, shown in this annex, meet the requirements of the mandate given under the EU Construction Product Directive (89/106/EEC).

Compliance with these clauses confers a presumption of fitness of the construction product covered by this European Standard for its intended use(s).

This Annex ZA covers kits for pressure differential systems as given in Clause 1 of this standard.

WARNING Other requirements and other EU Directives, not affecting the fitness of intended use(s), can be applicable to the construction product falling within the scope of this standard.

NOTE In addition to the specific clauses relating to dangerous substances contained in this European Standard, there may be other requirements applicable to the kits falling within its scope (e.g. transposed European legislation and national laws, regulations and administrative provisions). In order to meet the provisions of the EU Construction Products Directive, these requirements need also to be complied with, when and where they apply. An informative database of European and national provisions on dangerous substances is available at the Construction web site on EUROPA (accessed through <http://europa.eu.int/comm/enterprise/construction/internal/dangsub/dangmain.htm>).

Construction product: Pressure differential system kits.

Intended uses: Life safety.

Table ZA.1 — Relevant clauses for pressure differential system kits

Essential characteristics	Requirement clauses in this standard	Levels and/or classes	Notes
Nominal activation condition/sensitivity	11.4.2.1 11.4.2.3 11.5.2.4		
Response delay	11.4.2.4		
Operational reliability	11		With the exception of 11.3.2.5, 11.6.1 and 11.6.4.1
Effectiveness of smoke/hot gas extraction	5.2, 7, 8, 9		With the exception of 7.4.2.1, 8.2.1, 8.2.4, 8.2.7, 8.2.8 and 9.2.6
Performance parameters under fire conditions	6		
Pressurization performance	4, 5		With the exception of 4.3.2.4
Fire resistance – Integrity E	11.8	See prEN 13501-3 and prEN 13501-4	
Fire resistance – Insulation I	11.8	See prEN 13501-3 and prEN 13501-4	
Fire resistance – Smoke leakage	11.8, Annex A	See prEN 13501-3 and prEN 13501-4	
Fire resistance – Mechanical stability	11.8		
Fire resistance – Maintenance of cross section	11.8		

ZA.2 Procedure for the attestation of conformity of pressure differential system kits

The system of attestation of conformity for pressure differential system kits indicated in Table ZA.1, in accordance with the Decision of the Commission as given in Annex III of the mandate, is shown in Table ZA.2 for the indicated intended use(s) and relevant level(s) or class(es):

Table ZA.2 — Attestation of conformity system

Product	Intended use	Level(s) or class(es)	Attestation of conformity system
Pressure differential system kits	Life safety	See prEN 13501-3 and prEN 13501-4	1
System 1: See CPD annex III.2(i), without audit testing of samples			

The attestation of conformity of the pressure differential system kits in Table ZA.1 shall be based on the evaluation of conformity procedures indicated in Table ZA.3 resulting from application of the clauses of this European Standard indicated therein.

Table ZA.3 — Assignment of evaluation of conformity tasks under system 1

Tasks		Content of the task	Evaluation of conformity clauses to apply
Tasks under the responsibility of the manufacturer	Factory production control (FPC)	Parameters related to all relevant characteristics of Table ZA.1	16.3
Tasks under the responsibility of the product certification body	Initial type testing	All relevant characteristics of Table ZA.1	16.2
	Initial inspection of factory and of FPC	Parameters related to all relevant characteristics of Table ZA.1	16.3
	Continuous surveillance, assessment and approval of FPC	Parameters related to all relevant characteristics of Table ZA.1	16.3

ZA.3 CE Marking

The manufacturer or his authorised representative established within the EEA is responsible for the affixing of the CE marking. The CE marking symbol to affix shall be in accordance with Directive 93/68/EC and shall be shown on the packaging or on the accompanying commercial documents e.g. a delivery note). The following information shall accompany the CE marking symbol:

- the identification number of the product certification body;
- the name or identifying mark, and registered address, of the supplier;
- the last two digits of the year of CE marking;
- the number of the EC Certificate of Conformity;
- a reference to this European Standard (EN 12101-6);
- a description of the kit;
- information to identify the performance (or intended performance) of the kit in relation to the relevant essential characteristics listed in Table ZA.1, by reference to the detailed engineering plan, to be held by the supplier if not included with the commercial documents.

Figure ZA.1 gives an example of the information to be given on the commercial documents.

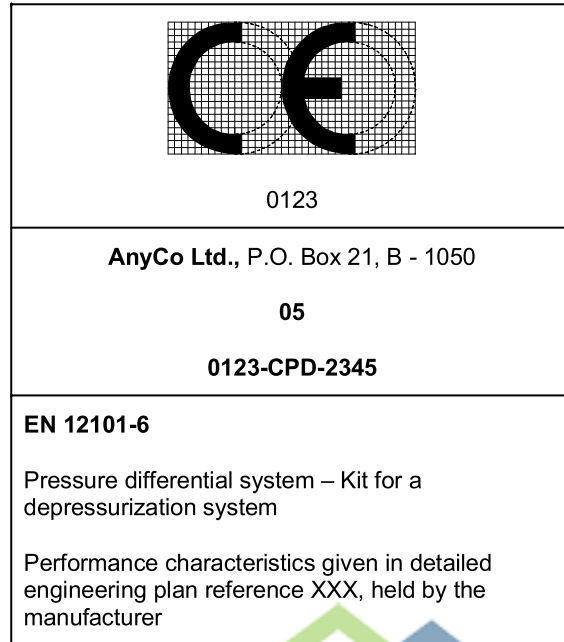

Figure ZA.1 — Example CE marking information

In addition to the specific information relating to dangerous substances shown above, the product should also be accompanied, when and where required and in the appropriate form, by documentation listing any other legislation on dangerous substances for which compliance is claimed, together with any information required by that legislation.

NOTE European legislation without national derogations need not be mentioned.

ZA.4 EC certificate and declaration of conformity

The manufacturer or his agent established in the EEA, shall prepare and retain a declaration of conformity, which authorises the affixing of the CE marking. This declaration shall include:

- name and address of the manufacturer, or his authorised representative established in the EEA, and the place of production;
- description of the product (type, identification, use), and a copy of the information accompanying the CE marking;
- provisions to which the product conforms (i.e. Annex ZA of this EN);
- particular conditions applicable to the use of the product (if necessary);
- name and address (or identification number) of the approved body (bodies);
- name of, and position held by, the person empowered to sign the declaration on behalf of the manufacturer or of his authorised representative.

The declaration shall contain a certificate of conformity with, in addition to the information above, the following information:

- the name and address of the certification body;
- the certificate number;
- conditions and period of validity of the certificate, where applicable;
- name of, and position held by, the person empowered to sign the certificate.

The declaration and certificate shall be presented in the language(s) of the Member State of use of the product.



Bibliography

- [1] prEN 1991-2-4, *Eurocode 1 — Basis of design and actions on structures — Part 2-4: Actions on structures — Wind actions*
- [2] CR 12101-5, *Smoke and heat control systems — Part 5: Guidelines on the functional recommendations and calculation methods for smoke and heat exhaust ventilation systems*
- [3] EN 12101-2, *Smoke and heat control systems — Part 2: Specification for natural smoke and heat exhaust ventilators*
- [4] EN 12101-3, *Smoke and heat control systems — Part 3: Specification for powered smoke and heat exhaust ventilators*
- [5] prEN 12101-8, *Smoke and heat control systems — Part 8: Specification for smoke control dampers*
- [6] ISO 8528, *Requirements for generating plant*





BSI — British Standards Institution

BSI is the independent national body responsible for preparing British Standards. It presents the UK view on standards in Europe and at the international level. It is incorporated by Royal Charter.

Revisions

British Standards are updated by amendment or revision. Users of British Standards should make sure that they possess the latest amendments or editions.

It is the constant aim of BSI to improve the quality of our products and services. We would be grateful if anyone finding an inaccuracy or ambiguity while using this British Standard would inform the Secretary of the technical committee responsible, the identity of which can be found on the inside front cover. Tel: +44 (0)20 8996 9000. Fax: +44 (0)20 8996 7400.

BSI offers members an individual updating service called PLUS which ensures that subscribers automatically receive the latest editions of standards.

Buying standards

Orders for all BSI, international and foreign standards publications should be addressed to Customer Services. Tel: +44 (0)20 8996 9001. Fax: +44 (0)20 8996 7001. Email: orders@bsi-global.com. Standards are also available from the BSI website at <http://www.bsi-global.com>.

In response to orders for international standards, it is BSI policy to supply the BSI implementation of those that have been published as British Standards, unless otherwise requested.

Information on standards

BSI provides a wide range of information on national, European and international standards through its Library and its Technical Help to Exporters Service. Various BSI electronic information services are also available which give details on all its products and services. Contact the Information Centre. Tel: +44 (0)20 8996 7111. Fax: +44 (0)20 8996 7048. Email: info@bsi-global.com.

Subscribing members of BSI are kept up to date with standards developments and receive substantial discounts on the purchase price of standards. For details of these and other benefits contact Membership Administration. Tel: +44 (0)20 8996 7002. Fax: +44 (0)20 8996 7001. Email: membership@bsi-global.com.

Information regarding online access to British Standards via British Standards Online can be found at <http://www.bsi-global.com/bsonline>.

Further information about BSI is available on the BSI website at <http://www.bsi-global.com>.

Copyright

Copyright subsists in all BSI publications. BSI also holds the copyright, in the UK, of the publications of the international standardization bodies. Except as permitted under the Copyright, Designs and Patents Act 1988 no extract may be reproduced, stored in a retrieval system or transmitted in any form or by any means – electronic, photocopying, recording or otherwise – without prior written permission from BSI.

This does not preclude the free use, in the course of implementing the standard, of necessary details such as symbols, and size, type or grade designations. If these details are to be used for any other purpose than implementation then the prior written permission of BSI must be obtained.

Details and advice can be obtained from the Copyright & Licensing Manager. Tel: +44 (0)20 8996 7070. Fax: +44 (0)20 8996 7553. Email: copyright@bsi-global.com.